

SERIE

D

2024\_LINE\_1

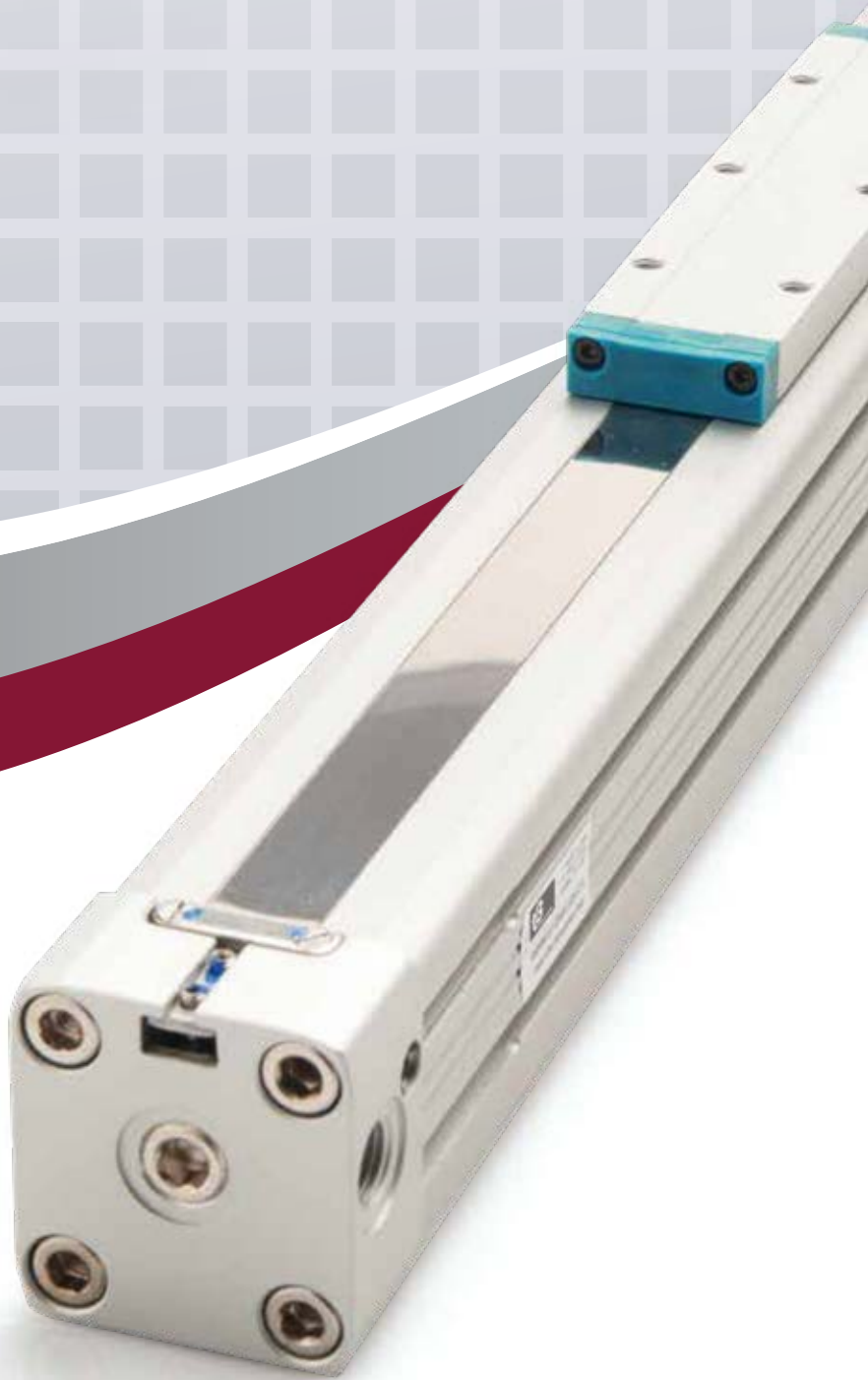

**Cilindri senza stelo**

*Rodless cylinders*



**CARATTERISTICHE TECNICHE - TECHNICAL CHARACTERISTICS**

<b>Pressione di esercizio</b> <i>Working pressure</i>	0,5 ÷ 8 bar
<b>Temperatura di esercizio</b> <i>Working temperature</i>	0 ÷ +80°C (-10°C con aria secca - <i>with dry air</i> )
<b>Velocità massima</b> <i>Maximum speed</i>	1 m/s
<b>Versioni - Versions</b>	doppio effetto - <i>double acting</i>
<b>Alesaggi - Bores</b>	∅ 16 - 25 - 32 - 40 - 50 - 63
<b>Corse - Strokes</b>	vedere tabelle corse standard - <i>see standard stroke tables</i>
<b>Fluido - Fluid</b>	aria compressa filtrata, non lubrificata - <i>compressed filtered, non lubricated air</i>

**CARATTERISTICHE COSTRUTTIVE - CONSTRUCTIVE CHARACTERISTICS**

<b>Testate - Covers</b>	alluminio anodizzato - <i>anodized aluminium</i>
<b>Tubo - Tube</b>	alluminio anodizzato - <i>anodized aluminium</i>
<b>Carro - Carriage</b>	alluminio anodizzato - <i>anodized aluminium</i>
<b>Bandella - Band</b>	acciaio inox - <i>stainless steel</i>
<b>Guarnizioni - Seals</b>	NBR
<b>Pistone - Piston</b>	alluminio pressofuso - <i>die cast aluminium</i>
<b>Viti - Screws</b>	acciaio zincato - <i>zinc coated steel</i>

 SERIE  
**D**
**CHIAVE DI CODIFICA**
**KEY CODE**

<b>D D M 0 5 0 . 1 0 0 0 . G S . C 1</b>	
<b>ALESAGGIO - BORE (∅)</b> 016-025-032-040-050-063	<b>CORSA - STROKE (mm)</b> vedere tabelle corse std <i>see std stroke tables</i>
<b>VERSIONE - VERSION</b> M magnetico <i>magnetic</i>	<b>GUARNIZIONI - SEALS</b> guarnizioni standard <i>standard seals</i> <b>GS</b> tutte le guarnizioni per alte temperature <i>all seals for high temperature</i> <b>VA</b>
<b>VERSIONE - VERSION</b> D doppio effetto <i>double acting</i>	<b>CARRO - CARRIAGE</b> C0 stretto <i>narrow</i> C1 standard <i>standard</i> C2 guidato <i>with guide</i> C3 guidato con cuscinetti a ricircolo di sfere <i>with guide and recirculating ball bearings</i> C4 guidato con guida prismatica <i>with guide and prismatic guide</i> C5 standard guidato <i>standard with guide</i>
<b>SERIE - SERIES</b> D cilindri senza stelo <i>rodless cylinders</i>	<b>OPZIONE - OPTION</b> S con viti in acciaio inox <i>with stainless steel screws</i>

**ESECUZIONI A RICHIESTA - ON REQUEST**

 Corse fino a 5700 mm - *Strokes up to 5700 mm*

## DIAGRAMMA AMMORTIZZO

### CUSHIONING DIAGRAM

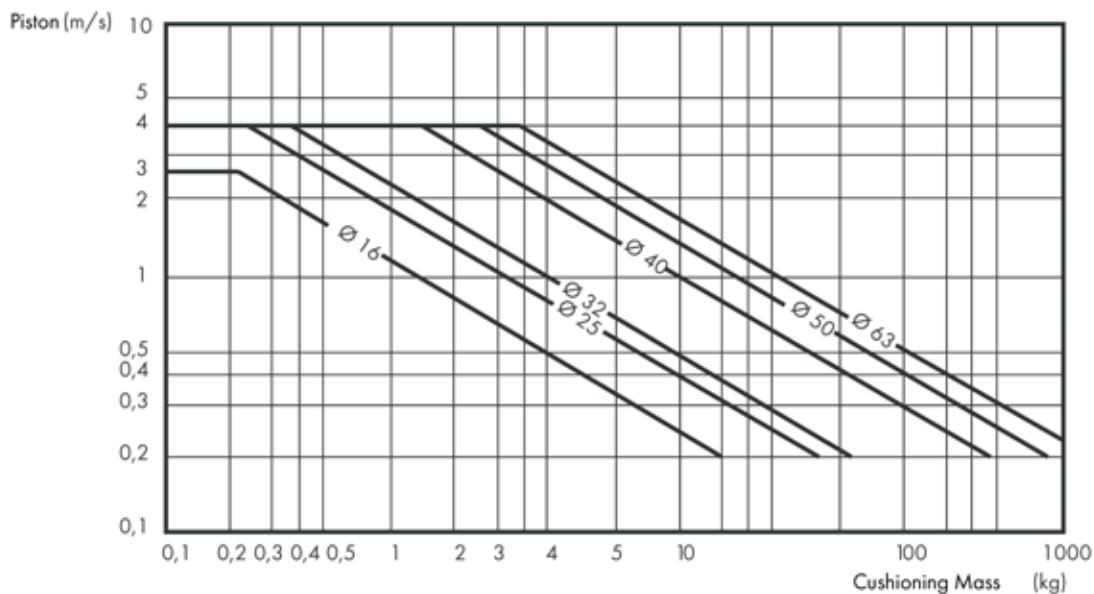

III Se i valori sopra indicati vengono superati, sono necessari ammortizzatori aggiuntivi; Velocità  $\geq 1$  m/s, si consigliano guarnizioni per alte temperature; La durata massima delle guarnizioni si ottiene con velocità  $< 1$  m/s.  
 III If the limits above are exceeded additional shock absorbers are necessary; With speeds  $\geq 1$  m/s high temperature seals are recommended; The Maximum seals lifetime will be obtained with speed  $< 1$  m/s.

SERIE  
**D**

CO

## DIAGRAMMA TEORICO CARICO AMMISSIBILE

### THEORETICAL ALLOWABLE LOAD

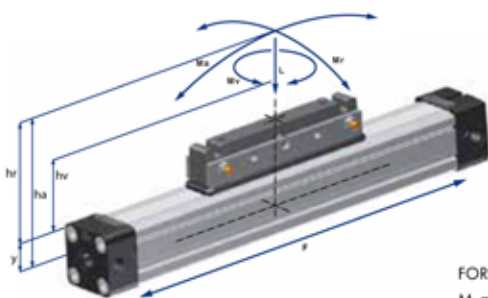

#### FORMULA / FORMULAS

$$M_a = F \cdot h_a$$

$$M_r = F \cdot h_r$$

$$M_v = F \cdot h_v$$

III I valori indicati in tabella sono validi per una velocità massima di 0,45 m/sec e una pressione massima di 6 bar. Nel caso di valori di carico non ben definiti ridurre i valori in tabella del 10-20%.

III The values in the chart are valid for a maximum speed of 0,45 m/sec and for a maximum pressure of 6 bar. In case of undefinable load values, values in the chart must be reduced by 10-20%.

### DIMENSIONI - DIMENSIONS

Ø	Y	Effect force (N)	Cushioning	Max allowed load	Max allowed bending moments (Nm)		Max allowed torque
		(6 bar)	(mm)	(N)	Ma axial	Mr radial	(N)
		F	S	L			Mv zentral
16	9	110	15	120	4	0,3	0,3
25	14	250	21	300	15	1	3
32	18	420	26	450	30	2	4,5
40	22	640	32	750	60	4	8

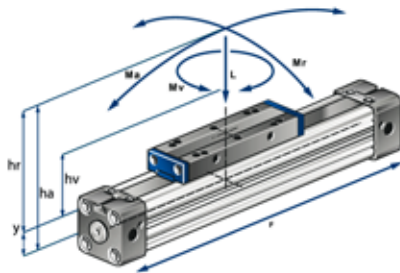
**DIAGRAMMA TEORICO CARICO AMMISSIBILE**
**THEORETICAL ALLOWABLE LOAD**

**DIMENSIONI - DIMENSIONS**

Ø	Y	Effect force (N)	Cushioning	Max allowed load	Max allowed bending moments (Nm)		Max allowed torque
		(6 bar)	(mm)	(N)	Ma axial	Mr radial	Mv zentral
16	9	110	15	120	4	0,3	0,5
25	14	250	21	300	15	1	3
32	18	420	26	450	30	2	4,5
40	22	640	32	750	60	4	8
50	28	1000	32	1200	115	7	15
63	36	1550	40	1650	200	8	24

**FORMULA / FORMULAS**

$$M_o = F \cdot h_o$$

$$M_r = F \cdot h_r$$

$$M_v = F \cdot h_v$$

!!! I valori indicati in tabella sono validi per una velocità massima di 0,45 m/sec e una pressione massima di 6 bar. Nel caso di valori di carico non ben definiti ridurre i valori in tabella del 10-20%.

!!! The values in the chart are valid for a maximum speed of 0,45 m/sec and for a maximum pressure of 6 bar. In case of undefinable load values, values in the chart must be reduced by 10-20%.

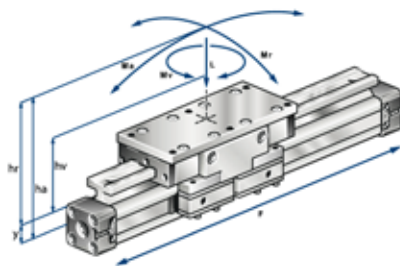
**DIAGRAMMA TEORICO CARICO AMMISSIBILE**
**THEORETICAL ALLOWABLE LOAD**

**DIMENSIONI - DIMENSIONS**

Ø	F (N) 6 bar	L max (N)	Mr max (Nm)	Ma max (Nm)	Mv max (Nm)
16	110	350	4	6	6
25	250	1000	14	40	40
32	420	2000	24	68	68
40	640	2800	37	103	103

**FORMULA / FORMULAS**

$$M_o = F \cdot h_o$$

$$M_r = F \cdot h_r$$

$$M_v = F \cdot h_v$$

!!! I valori indicati in tabella sono validi per una velocità massima di 0,2 m/sec e una pressione massima di 6 bar. Nel caso di valori di carico non ben definiti ridurre i valori in tabella del 10-20%.

!!! The values in the chart are valid for a maximum speed of 0,2 m/sec and for a maximum pressure of 6 bar. In case of undefinable load values, values in the chart must be reduced by 10-20%.

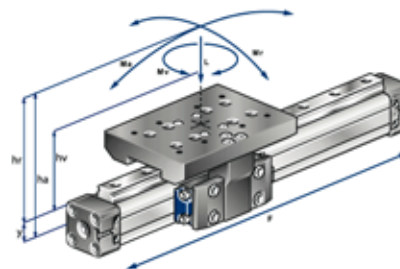
**SERIE D**
**DIAGRAMMA TEORICO CARICO AMMISSIBILE**
**THEORETICAL ALLOWABLE LOAD**

**FORMULA / FORMULAS**

$$M_o = F \cdot h_o$$

$$M_r = F \cdot h_r$$

$$M_v = F \cdot h_v$$

!!! I valori indicati in tabella sono validi per una velocità massima di 0,2 m/sec e una pressione massima di 6 bar. Nel caso di valori di carico non ben definiti ridurre i valori in tabella del 10-20%.

!!! The values in the chart are valid for a maximum speed of 0,2 m/sec and for a maximum pressure of 6 bar. In case of undefinable load values, values in the chart must be reduced by 10-20%.

**DIMENSIONI - DIMENSIONS**

Characteristics	16	25	32	40	50	63
effect force (6bar) (N)	110	250	420	640	1000	1550
cushioning (mm)	15	21	26	32	32	40
A (mm)	35	53	64	69	90	102
B (mm)	19	26	29,7	29,7	40	38,5
C/D/E/F (mm)	Dimensions according design					
G (mm)	30,3	38	55	54,5	65	75
H (mm)	31,5	40	57,5	57,5	68,5	85
I (mm)	31,5	40	57,5	57,5	65	85
Load forces max L (N)	500	1500	3000	3000	4000	4000
Moment Forces max La-Lr-Lv (N)	500	1500	3000	3000	4000	4000
Axial moments max Ma (Nm)	8	40	58	58	200	200
Radial moments max Mr (Nm)	4	15	23	23	70	70
Torsion moments max Mv (Nm)	8	40	58	58	200	200

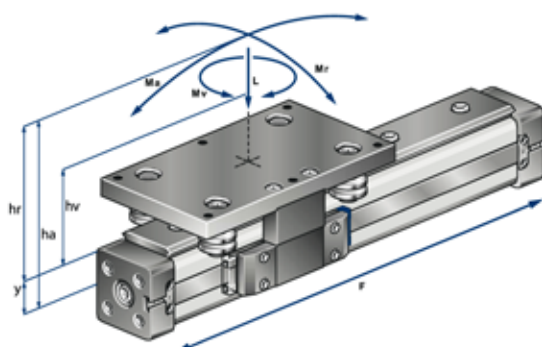
**DIAGRAMMA TEORICO CARICO AMMISSIBILE**
**THEORETICAL ALLOWABLE TORQUE**

**FORMULA / FORMULAS**

$$M_a = F \cdot h_a$$

$$M_r = F \cdot h_r$$

$$M_v = F \cdot h_v$$

!!! I valori indicati in tabella sono validi per una velocità massima di 0,2 m/sec e una pressione massima di 6 bar. Nel caso di valori di carico non ben definiti ridurre i valori in tabella del 10-20%.

!!! The values in the chart are valid for a maximum speed of 0,2 m/sec and for a maximum pressure of 6 bar. In case of undefinable load values, values in the chart must be reduced by 10-20%.

**DIMENSIONI - DIMENSIONS**

PLR - Movements	25	32	40	50
effect force (6bar) (N)	250	420	640	1000
A (mm)	53	64	72,5	88,5
B (mm)	20,5	26	28	28
C/D/E/F (mm)	Dimensions according design			
G (mm)	38	55,5	54,5	58,5
H (mm)	40	58	67,5	67,5
I (mm)	40	58	67,5	67,5
Load forces max L (N)	1400	3100	3100	3100
Moment forces max La, Lr, Lv (N)	1400	3100	3100	3100
Axial moments max Ma (Nm)	50	165	250	250
Radial moments max Mr (Nm)	14	65	90	90
Torsion moments max Mv (Nm)	50	165	250	250

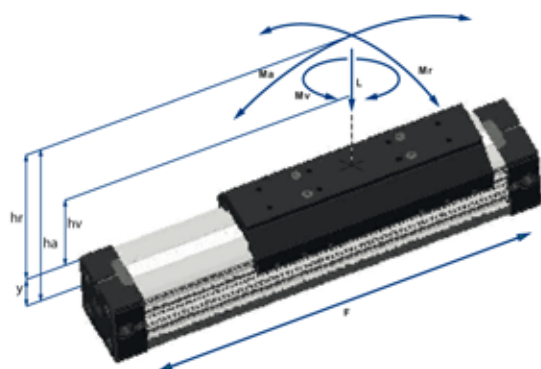
**SERIE**  
**D**
**DIAGRAMMA TEORICO CARICO AMMISSIBILE**
**THEORETICAL ALLOWABLE LOAD**

**FORMULA / FORMULAS**

$$M_a = F \cdot h_a$$

$$M_r = F \cdot h_r$$

$$M_v = F \cdot h_v$$

!!! I valori indicati in tabella sono validi per una velocità massima di 0,2 m/sec e una pressione massima di 6 bar. Nel caso di valori di carico non ben definiti ridurre i valori in tabella del 10-20%.

!!! The values in the chart are valid for a maximum speed of 0,2 m/sec and for a maximum pressure of 6 bar. In case of undefinable load values, values in the chart must be reduced by 10-20%.

**DIMENSIONI - DIMENSIONS**

Ø	Y	Effect force (N)	Cushioning	Max allowed load	Max allowed bending moments (Nm)		Max allowed torque
		(6 bar)	(mm)	(N)	Ma axial	Mr radial	Mv zentral
		F	S	L			(N)
32	18	420	26	495	39	15	39
40	22	640	32	825	99	35	99
50	28	1000	32	1320	170	58	170
63	36	1550	40	1815	315	105	317

**CILINDRO SENZA STELO CON CARRO STRETTO**  
*RODLESS CYLINDER WITH NARROW CARRIAGE*

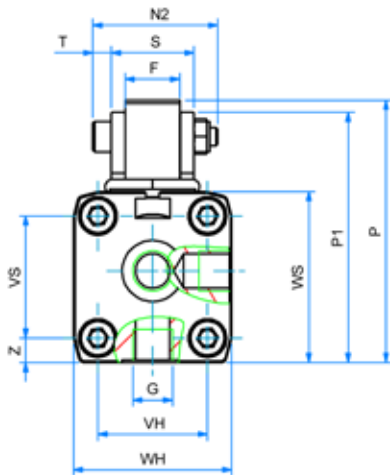

SERIE  
**D**

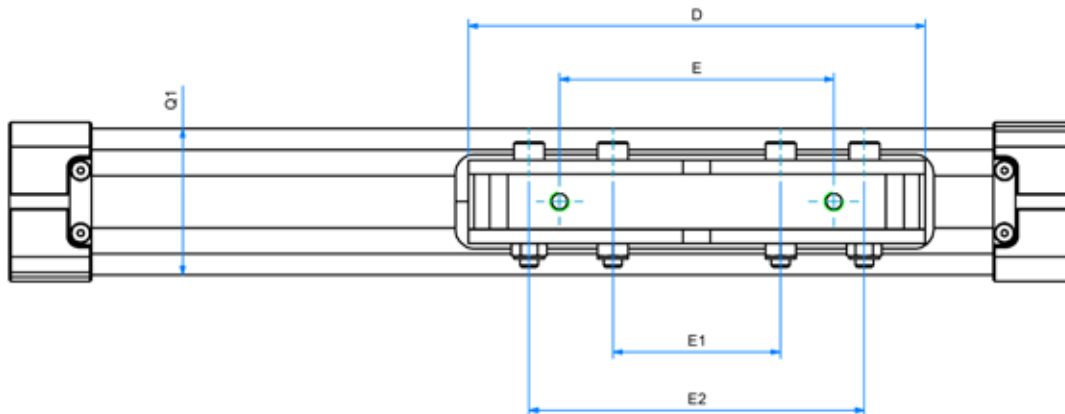
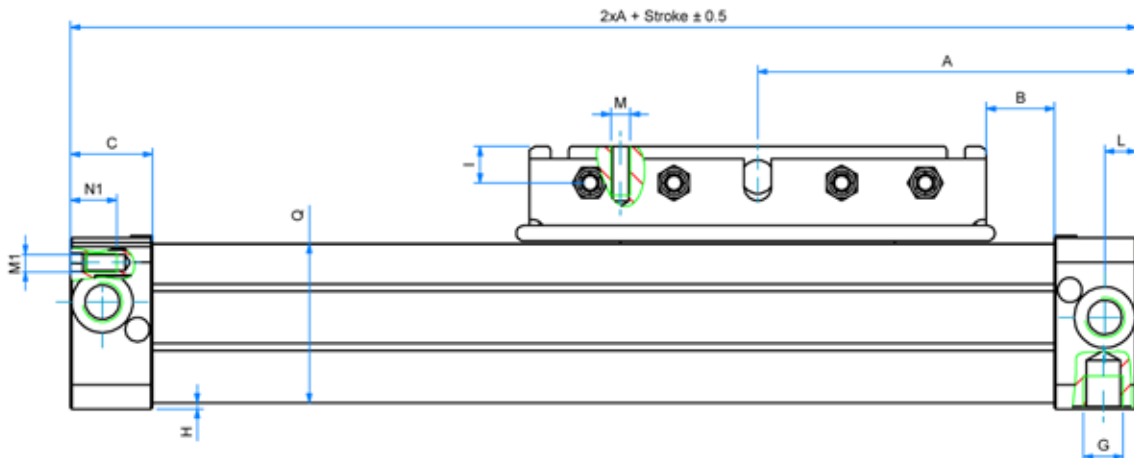

**CILINDRO SENZA STELO CON CARRO STRETTO**
**RODLESS CYLINDER WITH NARROW CARRIAGE**
**DIMENSIONI - DIMENSIONS**

Ø	16	25	32	40
A+	65	100	125	150
B	12	17	23	45
C	15	23	27	30
D	76	120	150	150
E	48	80	90	90
E1	32	50	55	55
F	10	15	18	18
G	M5	G1/8	G1/4	G1/4
I	6	13	12	12
L	5,5	8,5	10,5	15
M	M4	M5	M6	M6
M1	M3	M5	M6	M6
N1	7	10	14	17
N2	27	35	41	41
P	43,5	66	86	97
P1	37,5	53	74	85
QxQ1	24,5x25	36x36	52x51	58,5x59
E2	64	100	110	110
H	1	2	2	7
S	18	23	27	28
T	4	5	6	6
VH	18	27	36	54
WH	27	40	52	72
VS	18	27	40	54
WS	27	40	56	69
Z	4,5	6,5	8	9

+ = lunghezza corsa - stroke length

 SERIE  
**D**
**Ø CORSE STANDARD - STANDARD STROKES**

<b>016</b>	100 - 200 - 300 - 400 - 500 - 600 - 700 - 800 - 900 - 1000 - 1100 - 1200 - 1300 - 1400 - 1500 - 1600 - 1700 - 1800 - 1900 - 2000
<b>025</b>	100 - 200 - 300 - 400 - 500 - 600 - 700 - 800 - 900 - 1000 - 1100 - 1200 - 1300 - 1400 - 1500 - 1600 - 1700 - 1800 - 1900 - 2000
<b>032</b>	100 - 200 - 300 - 400 - 500 - 600 - 700 - 800 - 900 - 1000 - 1100 - 1200 - 1300 - 1400 - 1500 - 1600 - 1700 - 1800 - 1900 - 2000
<b>040</b>	100 - 200 - 300 - 400 - 500 - 600 - 700 - 800 - 900 - 1000 - 1100 - 1200 - 1300 - 1400 - 1500 - 1600 - 1700 - 1800 - 1900 - 2000
<b>050</b>	100 - 200 - 300 - 400 - 500 - 600 - 700 - 800 - 900 - 1000 - 1100 - 1200 - 1300 - 1400 - 1500 - 1600 - 1700 - 1800 - 1900 - 2000
<b>063</b>	100 - 200 - 300 - 400 - 500 - 600 - 700 - 800 - 900 - 1000 - 1100 - 1200 - 1300 - 1400 - 1500 - 1600 - 1700 - 1800 - 1900 - 2000



**CILINDRO SENZA STELO CON CARRO STANDARD**  
 RODLESS CYLINDER WITH STANDARD CARRIAGE

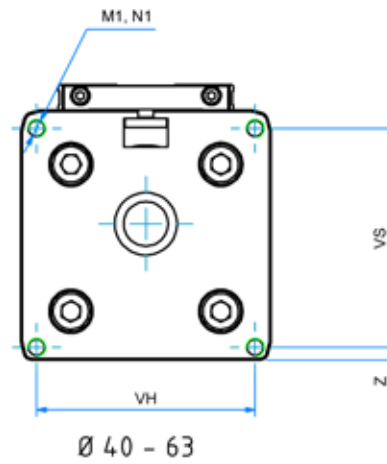
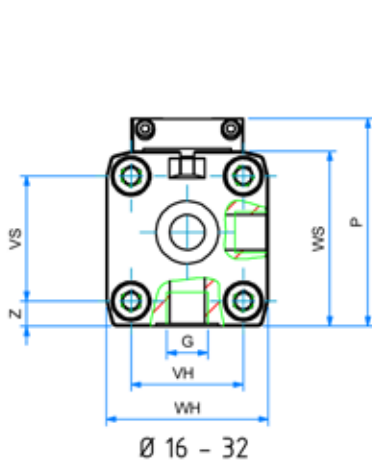

SERIE  
**D**

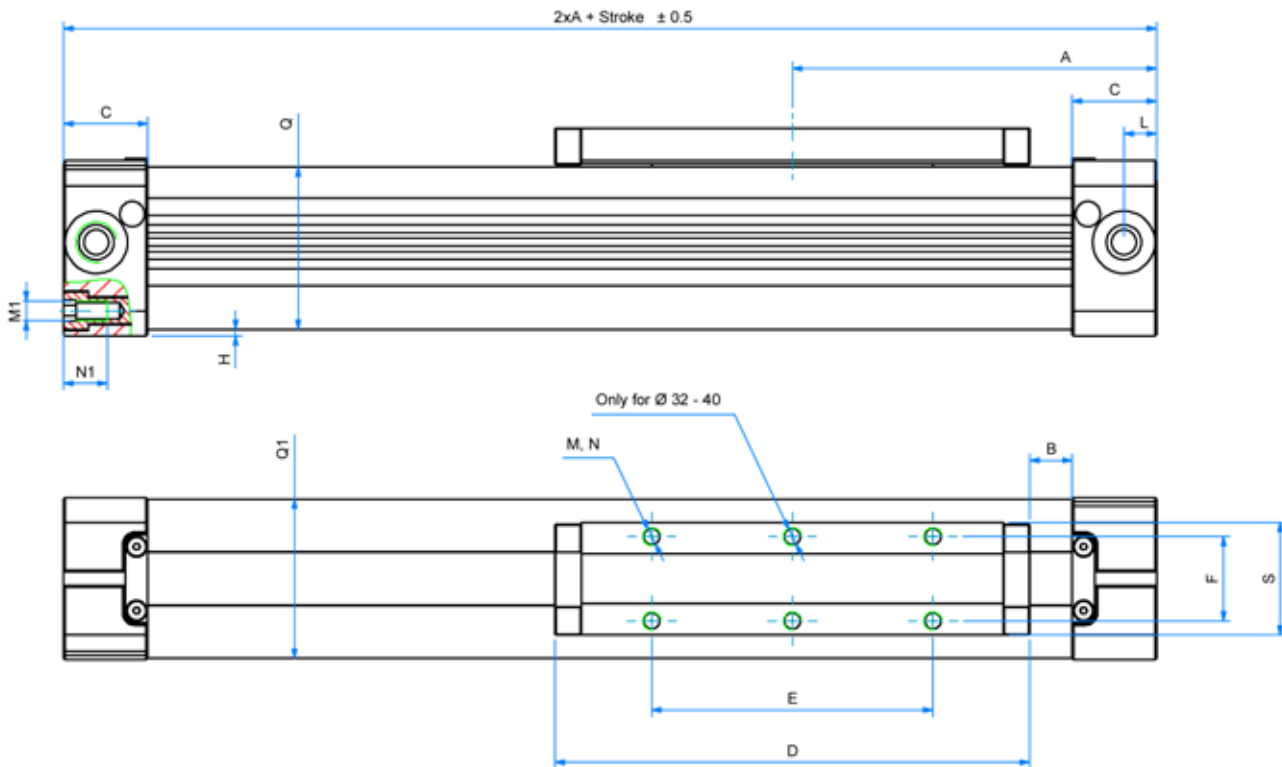



**CILINDRO SENZA STELO CON CARRO STANDARD**
**RODLESS CYLINDER WITH STANDARD CARRIAGE**

<b>DIMENSIONI - DIMENSIONS</b>						
<b>Ø</b>	<b>16</b>	<b>25</b>	<b>32</b>	<b>40</b>	<b>50</b>	<b>63</b>
<b>A+</b>	65	100	125	150	175	215
<b>B</b>	15,5	21	22	44	42	47,5
<b>C</b>	15	23	27	30	33	50
<b>D</b>	69	111	152	152	200	235
<b>E</b>	36	65	90	90	110	155
<b>F</b>	16,5	25	27	27	27	36
<b>G</b>	M5	G1/8	G1/4	G1/4	G1/4	G3/8
<b>H</b>	1	2	2	6,75	0,5	1,5
<b>L</b>	5,5	8,5	10,5	15	11,7	25
<b>M</b>	M4	M5	M6	M6	M6	M8
<b>M1</b>	M3	M5	M6	M6	M6	M8
<b>N</b>	7	10	7	10	6	15
<b>N1</b>	7	12	14	17	18	18
<b>P</b>	36,5	52,5	66,5	80	88	123
<b>QxQ1</b>	24,5x25	36x36	52x51	58,5x59	77x78	102x102
<b>S</b>	22	33	36	36,4	56	50
<b>VS</b>	18	27	40	54	70	78
<b>VH</b>	18	27	36	54	70	78
<b>WS</b>	27	40	56	69	80	106
<b>WH</b>	27	40	52	72	80	106
<b>Z</b>	4,5	6,5	8	9	4	14,5

+ = lunghezza corsa - stroke length

SERIE  
**D**

**Ø CORSE STANDARD - STANDARD STROKES**

<b>016</b>	100 - 200 - 300 - 400 - 500 - 600 - 700 - 800 - 900 - 1000 - 1100 - 1200 - 1300 - 1400 - 1500 - 1600 - 1700 - 1800 - 1900 - 2000
<b>025</b>	100 - 200 - 300 - 400 - 500 - 600 - 700 - 800 - 900 - 1000 - 1100 - 1200 - 1300 - 1400 - 1500 - 1600 - 1700 - 1800 - 1900 - 2000
<b>032</b>	100 - 200 - 300 - 400 - 500 - 600 - 700 - 800 - 900 - 1000 - 1100 - 1200 - 1300 - 1400 - 1500 - 1600 - 1700 - 1800 - 1900 - 2000
<b>040</b>	100 - 200 - 300 - 400 - 500 - 600 - 700 - 800 - 900 - 1000 - 1100 - 1200 - 1300 - 1400 - 1500 - 1600 - 1700 - 1800 - 1900 - 2000
<b>050</b>	100 - 200 - 300 - 400 - 500 - 600 - 700 - 800 - 900 - 1000 - 1100 - 1200 - 1300 - 1400 - 1500 - 1600 - 1700 - 1800 - 1900 - 2000
<b>063</b>	100 - 200 - 300 - 400 - 500 - 600 - 700 - 800 - 900 - 1000 - 1100 - 1200 - 1300 - 1400 - 1500 - 1600 - 1700 - 1800 - 1900 - 2000

**CILINDRO SENZA STELO CON CARRO GUIDATO**  
 RODLESS CYLINDER WITH GUIDED CARRIAGE

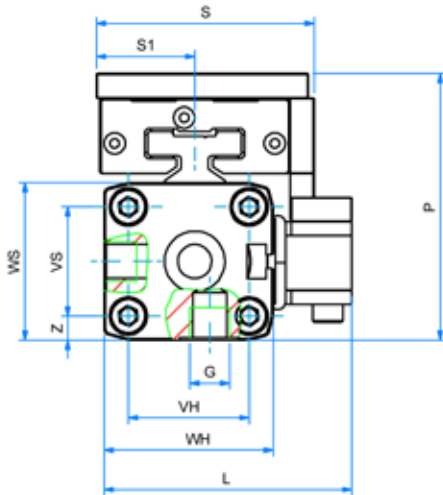

SERIE  
**D**

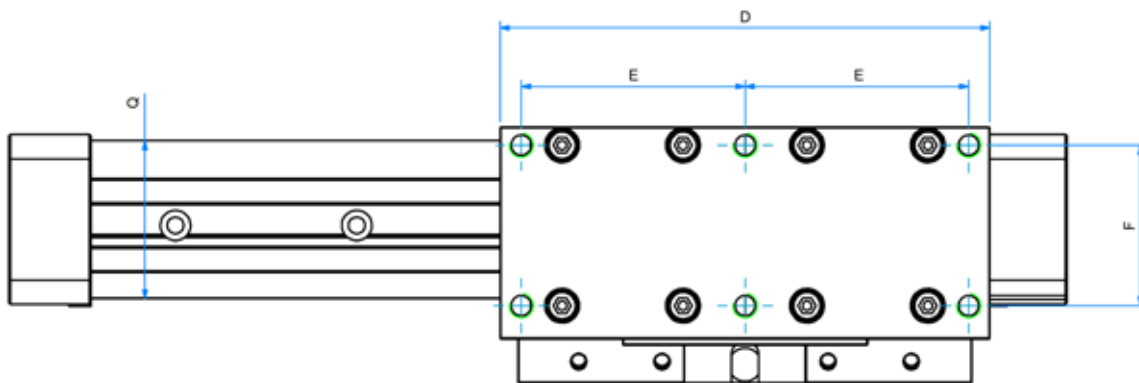
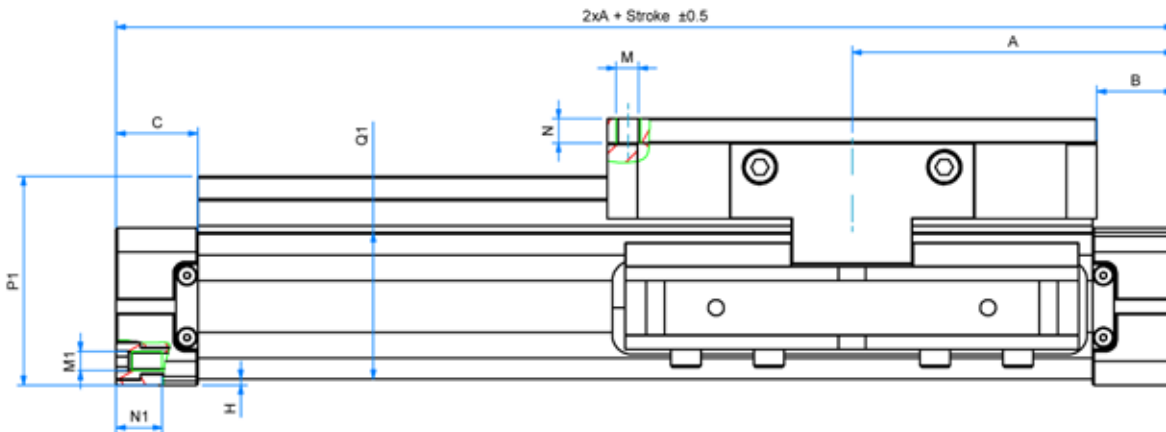

**CILINDRO SENZA STELO CON CARRO GUIDATO**
**RODLESS CYLINDER WITH GUIDED CARRIAGE**

<b>DIMENSIONI - DIMENSIONS</b>				
<b>Ø</b>	<b>016</b>	<b>025</b>	<b>032</b>	<b>040</b>
<b>A+</b>	65	100	125	150
<b>C</b>	15	23	27	30
<b>D</b>	90	162	162	162
<b>E</b>	20	74	74	74
<b>F</b>	36	53	53	53
<b>G</b>	M5	G1/8	G1/4	G1/4
<b>H</b>	1,5	2	2	7
<b>L</b>	42,3	59,5	82	93
<b>M</b>	M4	M6	M6	M6
<b>N</b>	10	8	8	8
<b>M1</b>	M3	M5	M6	M6
<b>N1</b>	7	10	14	17
<b>P</b>	48,5	76	88,5	103
<b>QxQ1</b>	24,5x25	36x36	52x48	58x58
<b>S</b>	63	70	70	70
<b>S1</b>	31,5	32,5	32,5	32,5
<b>VH</b>	18	27	40	54
<b>VS</b>	18	27	36	54
<b>WH</b>	27	40	52	69
<b>WS</b>	27	40	52	72
<b>Z</b>	4,5	6,5	8	9

+ = lunghezza corsa - stroke length

<b>Ø</b>	<b>CORSE STANDARD - STANDARD STROKES</b>
<b>016</b>	100 - 200 - 300 - 400 - 500 - 600 - 700 - 800 - 900 - 1000 - 1100 - 1200 - 1300 - 1400 - 1500 - 1600 - 1700 - 1800 - 1900 - 2000
<b>025</b>	100 - 200 - 300 - 400 - 500 - 600 - 700 - 800 - 900 - 1000 - 1100 - 1200 - 1300 - 1400 - 1500 - 1600 - 1700 - 1800 - 1900 - 2000
<b>032</b>	100 - 200 - 300 - 400 - 500 - 600 - 700 - 800 - 900 - 1000 - 1100 - 1200 - 1300 - 1400 - 1500 - 1600 - 1700 - 1800 - 1900 - 2000
<b>040</b>	100 - 200 - 300 - 400 - 500 - 600 - 700 - 800 - 900 - 1000 - 1100 - 1200 - 1300 - 1400 - 1500 - 1600 - 1700 - 1800 - 1900 - 2000

SERIE  
**D**

**CILINDRO SENZA STELO CON CARRO GUIDATO E CUSCINETTI A RICIRCOLO DI SFERE**  
**RODLESS CYLINDER WITH GUIDED CARRIAGE AND RECIRCULATING BALL BEARINGS**

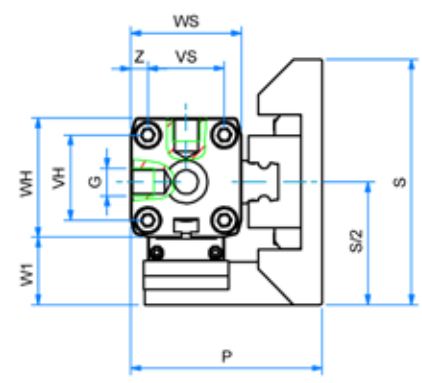
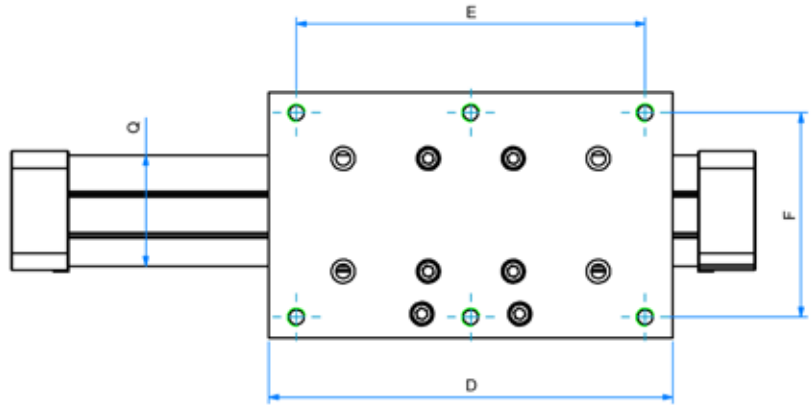
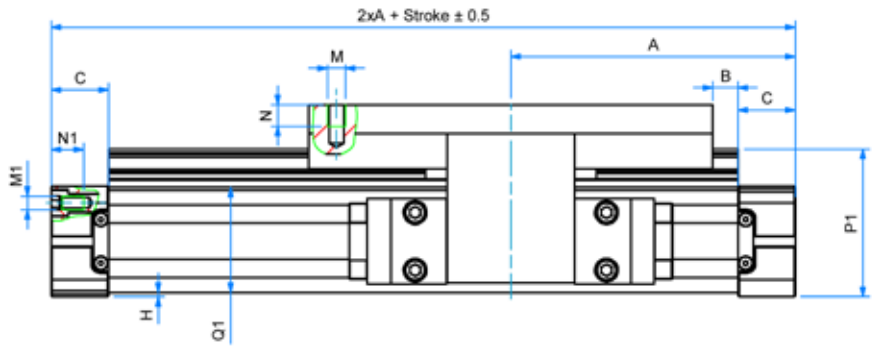

SERIE  
**D**

**ADATTATORE DECELERATORE - SHOCK ABSORBER ADAPTER**

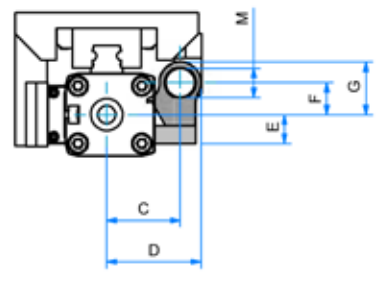
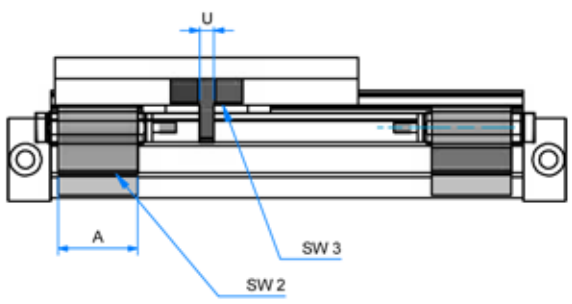

!!! Deceleratore non fornito  
 !!! Shock absorber adapter non supplied

**CILINDRO SENZA STELO CON CARRO GUIDATO E CUSCINETTI A RICIRCOLO DI SFERE**
**RODLESS CYLINDER WITH GUIDED CARRIAGE AND RECIRCULATING BALL BEARINGS**
**DIMENSIONI - DIMENSIONS**

Ø	016	025	032	040	050	063
A+	65	100	125	150	175	215
B	5	4,5	3	25	34,5	57,5
C	15	23	27	30	33	50
D	90	145	190	190	215	215
E	70	125	164	164	180	180
F	36	64	96	96	110	140
G	M5	G1/8	G1/4	G1/4	G1/4	G3/8
H	1	2	2	7	1	2
M	M4	M6	M8	M8	M8	M8
N	10	12	13	18	20	20
M1	M3	M5	M6	M6	M6	M8
N1	7	10	14	17	18	18
P	48,9	73	90	105	130	155
PI	34	52,3	69,3	84,3	102,3	128,3
QxQ1	24,5x25	36x36	48x52	58x58	77x78	102x102
S	63	80	115	115	130	170
S2	31,5	40	57,5	57,5	65	85
VH	18	27	40	54	70	78
VS	18	27	36	54	70	78
WH	27	40	56	69	80	106
WS	27	40	52	72	80	106
W1	18	20	30,5	24,5	28,5	31,5
Z	4,5	6,5	8	9	5	14

+ = lunghezza corsa - stroke length

 SERIE  
**D**
**ADATTATORE DECELERATORE - SHOCK ABSORBER ADAPTER**
**DIMENSIONI - DIMENSIONS**

Ø	016	025	032	040	050
A	28	50	50	50	70
B	43,2	81,3	95,5	94,5	102,5
C	22,2	31,4	46,2	47,2	63
D	29,2	41,4	59,2	60,2	79
E	13,2	11,7	19,4	19,4	11
F	9	15,5	20	20	31
G	16	25,5	33	33	59
M	M10x1	M14x1,5	M20x1,5	M20x1,5	M25x1,5
U	8	9	9	9	-
SW2	3	4	4	4	-
SW3	3	4	4	4	-

**Ø CORSE STANDARD - STANDARD STROKES**

016	100 - 200 - 300 - 400 - 500 - 600 - 700 - 800 - 900 - 1000 - 1100 - 1200 - 1300 - 1400 - 1500 - 1600 - 1700 - 1800 - 1900 - 2000
025	100 - 200 - 300 - 400 - 500 - 600 - 700 - 800 - 900 - 1000 - 1100 - 1200 - 1300 - 1400 - 1500 - 1600 - 1700 - 1800 - 1900 - 2000
032	100 - 200 - 300 - 400 - 500 - 600 - 700 - 800 - 900 - 1000 - 1100 - 1200 - 1300 - 1400 - 1500 - 1600 - 1700 - 1800 - 1900 - 2000
040	100 - 200 - 300 - 400 - 500 - 600 - 700 - 800 - 900 - 1000 - 1100 - 1200 - 1300 - 1400 - 1500 - 1600 - 1700 - 1800 - 1900 - 2000
050	100 - 200 - 300 - 400 - 500 - 600 - 700 - 800 - 900 - 1000 - 1100 - 1200 - 1300 - 1400 - 1500 - 1600 - 1700 - 1800 - 1900 - 2000
063	100 - 200 - 300 - 400 - 500 - 600 - 700 - 800 - 900 - 1000 - 1100 - 1200 - 1300 - 1400 - 1500 - 1600 - 1700 - 1800 - 1900 - 2000

**CILINDRO SENZA STELO CON CARRO GUIDATO E GUIDA PRISMatica**

RODLESS CYLINDER WITH GUIDED CARRIAGE AND PRISMATIC GUIDE

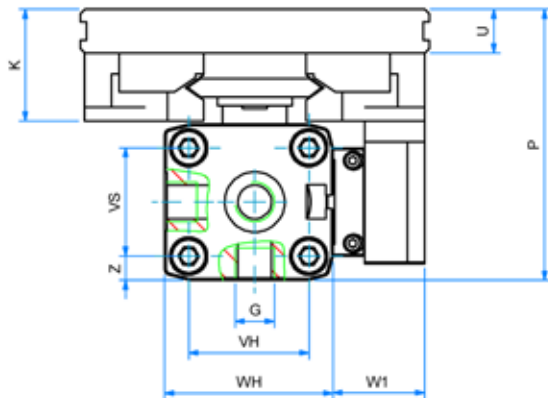

SERIE **D**

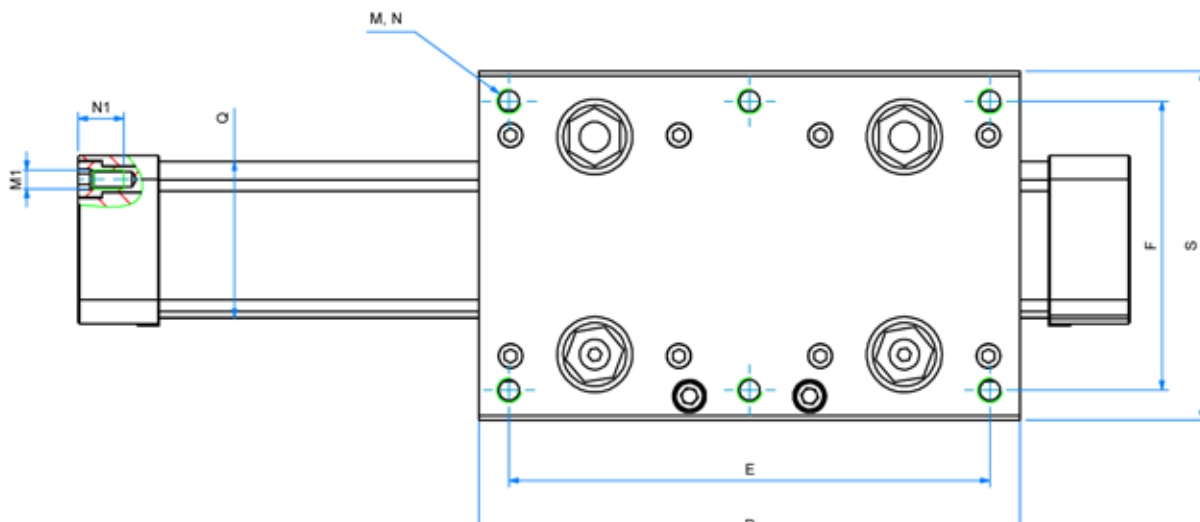
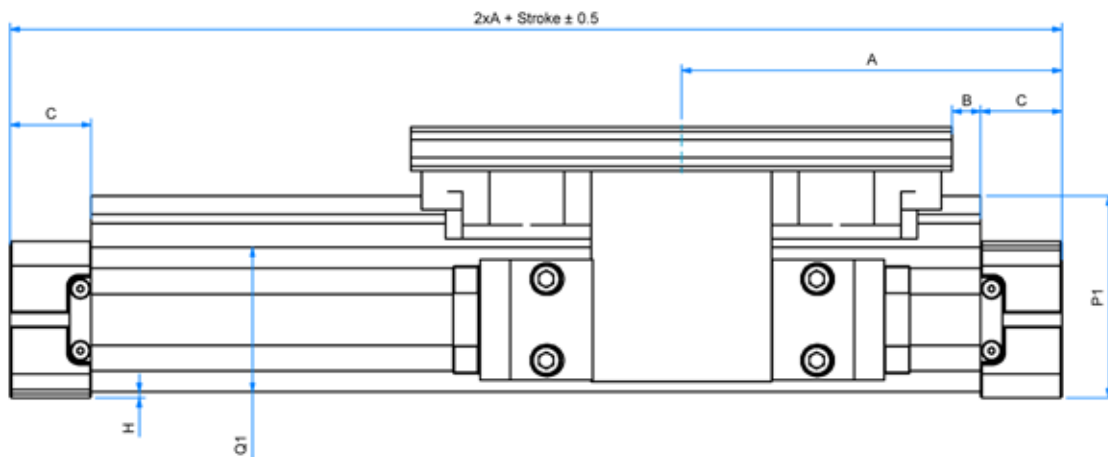

**CILINDRO SENZA STELO CON CARRO GUIDATO E GUIDA PRISMATICA**
**RODLESS CYLINDER WITH GUIDED CARRIAGE AND PRISMATIC GUIDE**

<b>DIMENSIONI - DIMENSIONS</b>				
<b>Ø</b>	<b>025</b>	<b>032</b>	<b>040</b>	<b>050</b>
<b>A+</b>	100	125	150	175
<b>B</b>	9,5	8	0	22
<b>C</b>	23	27	30	33
<b>D</b>	135	180	240	240
<b>E</b>	120	160	216	216
<b>F</b>	65	96	115	115
<b>G</b>	G1/8	G1/4	G1/4	G1/4
<b>H</b>	2	2	6,75	1
<b>K</b>	29,5	37	39	39
<b>M</b>	M6	M8	M8	M8
<b>N</b>	11	14,5	16,5	16,5
<b>M1</b>	M5	M6	M6	M6
<b>N1</b>	10	14	17	18
<b>P</b>	73,5	90	108,5	122
<b>P1</b>	50,5	64,5	84	97,5
<b>QxQ1</b>	36x36	52x48	58,5x59	77x78
<b>S</b>	80	116	135	135
<b>U</b>	11	14,5	16,5	16,5
<b>VH</b>	27	40	54	70
<b>VS</b>	27	36	54	70
<b>WH</b>	40	56	69	80
<b>W1</b>	22	32	34,5	31
<b>Z</b>	6,5	8	9	5

+ = lunghezza corsa - stroke length

SERIE  
**D**

<b>Ø</b>	<b>CORSE STANDARD - STANDARD STROKES</b>
<b>025</b>	100 - 200 - 300 - 400 - 500 - 600 - 700 - 800 - 900 - 1000 - 1100 - 1200 - 1300 - 1400 - 1500 - 1600 - 1700 - 1800 - 1900 - 2000
<b>032</b>	100 - 200 - 300 - 400 - 500 - 600 - 700 - 800 - 900 - 1000 - 1100 - 1200 - 1300 - 1400 - 1500 - 1600 - 1700 - 1800 - 1900 - 2000
<b>040</b>	100 - 200 - 300 - 400 - 500 - 600 - 700 - 800 - 900 - 1000 - 1100 - 1200 - 1300 - 1400 - 1500 - 1600 - 1700 - 1800 - 1900 - 2000
<b>050</b>	100 - 200 - 300 - 400 - 500 - 600 - 700 - 800 - 900 - 1000 - 1100 - 1200 - 1300 - 1400 - 1500 - 1600 - 1700 - 1800 - 1900 - 2000



**CILINDRO SENZA STELO CON CARRO STANDARD GUIDATO**  
**RODLESS CYLINDER WITH STANDARD GUIDED CARRIAGE**

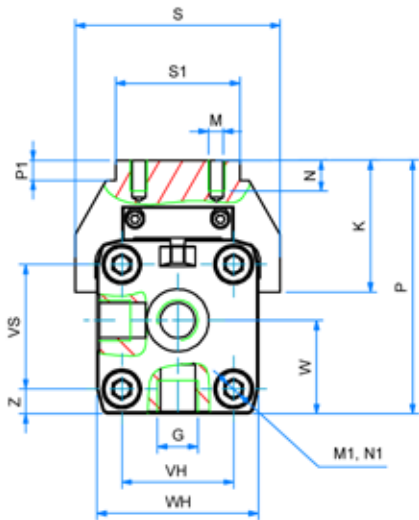

SERIE  
**D**

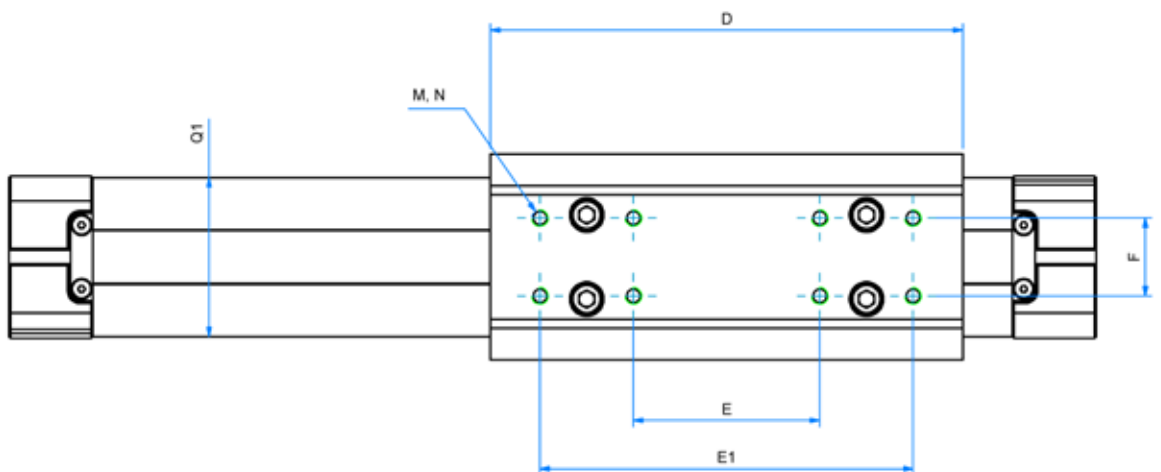
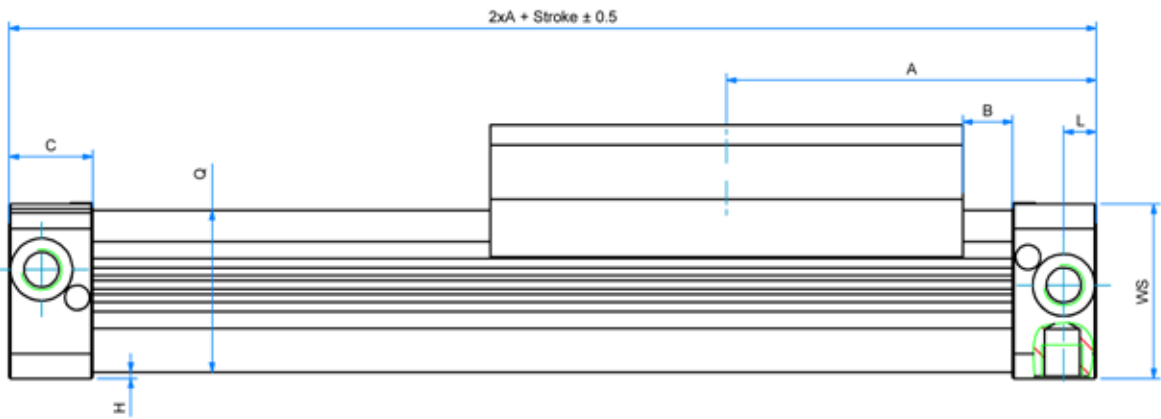

**CILINDRO SENZA STELO CON CARRO STANDARD GUIDATO**
**RODLESS CYLINDER WITH STANDARD GUIDED CARRIAGE**
**DIMENSIONI - DIMENSIONS**

Ø	32	40	50	63
A+	125	150	175	215
B	22	12,5	17,5	6,5
C	27	30	33	55
D	152	215	250	320
E	60	68	84	120
E1	120	160	190	240
F	25	25	25	25
G	G1/4	G1/4	G1/4	G3/8
H	2	7	0,5	1,5
K	42,5	44	48,5	56
L	10,5	15	11,7	25
M	M5	M8	M8	M8
N	10	10	10	14
M1	M6	M6	M6	M8
N1	14	17	18	18
P	81,5	97,5	110	137
P1	6,5	6,5	6,5	5
QxQ1	52x51	58,5x59	77x78	102x102
S	66	79	92	116
S1	40	45	50	50
VH	36	54	70	78
VS	40	54	70	78
W	30	36	43,5	62,5
WH	52	72	80	106
WS	56	69	80	106
Z	8	9	4	14,5

+ = lunghezza corsa - stroke length

SERIE  
**D**

**Ø CORSE STANDARD - STANDARD STROKES**

<b>025</b>	100 - 200 - 300 - 400 - 500 - 600 - 700 - 800 - 900 - 1000 - 1100 - 1200 - 1300 - 1400 - 1500 - 1600 - 1700 - 1800 - 1900 - 2000
<b>032</b>	100 - 200 - 300 - 400 - 500 - 600 - 700 - 800 - 900 - 1000 - 1100 - 1200 - 1300 - 1400 - 1500 - 1600 - 1700 - 1800 - 1900 - 2000
<b>040</b>	100 - 200 - 300 - 400 - 500 - 600 - 700 - 800 - 900 - 1000 - 1100 - 1200 - 1300 - 1400 - 1500 - 1600 - 1700 - 1800 - 1900 - 2000
<b>050</b>	100 - 200 - 300 - 400 - 500 - 600 - 700 - 800 - 900 - 1000 - 1100 - 1200 - 1300 - 1400 - 1500 - 1600 - 1700 - 1800 - 1900 - 2000

## ACCESSORI DI FISSAGGIO CILINDRI SENZA STELO

RODLESS CYLINDER MOUNTING PARTS

### DIAGRAMMA DI FLESSIONE

DEFLECTION DIAGRAM

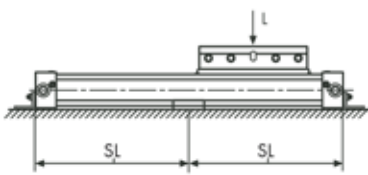
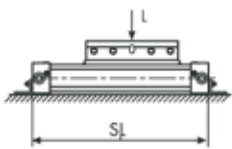
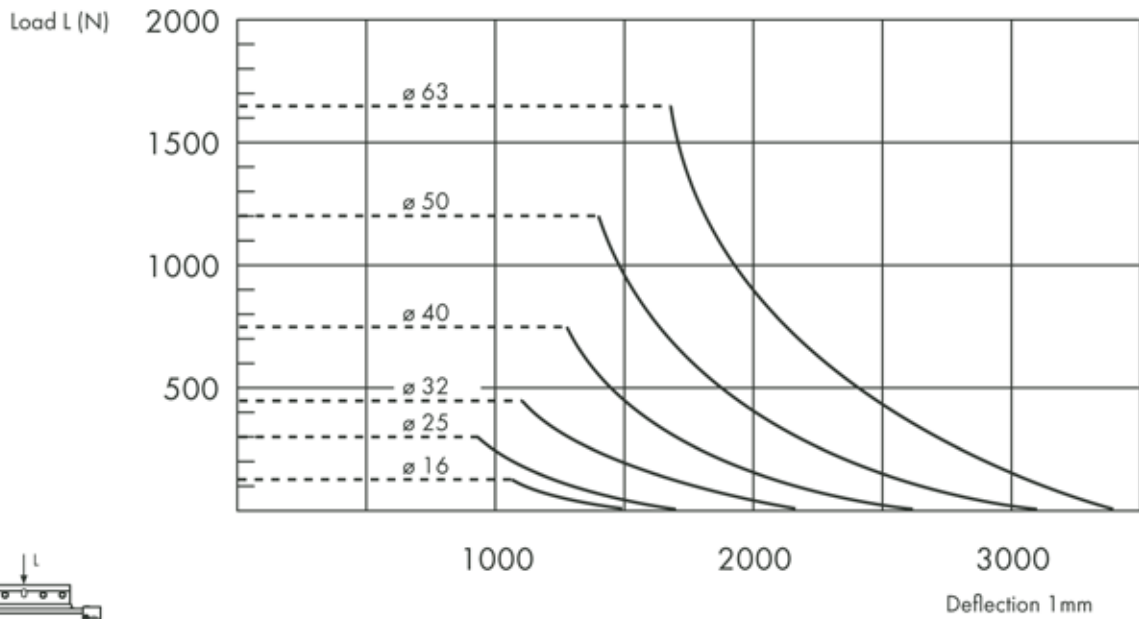

max. distance (SL) in mm - free of mounting No. 25

SERIE  
**D**

**PIEDINO BASSO**
**PBSS---**
**FOOT MOUNTING**

Ø 16-25

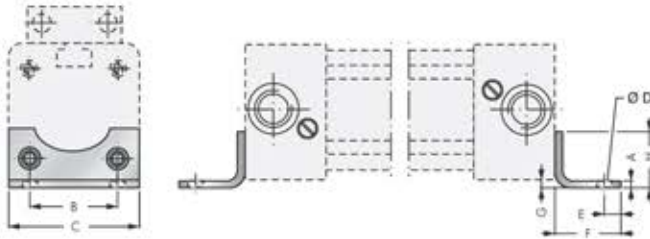

Ø 32 + 63

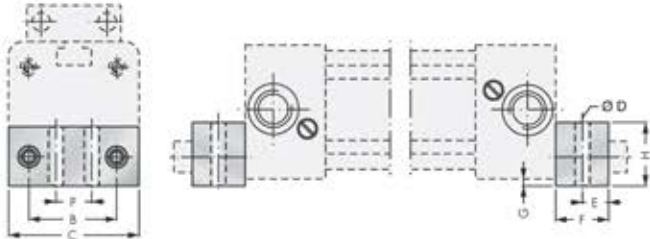
 MATERIALE:  
 ACCIAIO ZINCATO  
 MATERIAL:  
 ZINC COATED STEEL

**PIEDINO INTERMEDIO**
**PISS---**

 SERIE  
**D**
**MID SECTION FOOT MOUNTING**

Ø 16-25

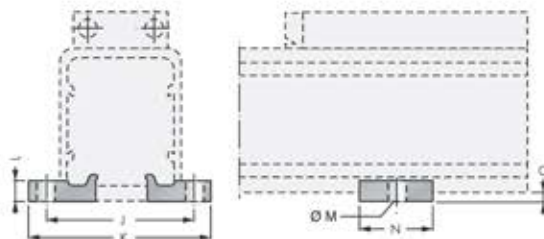

Ø 32 + 63

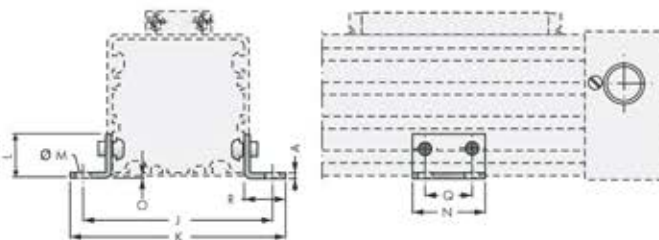
 MATERIALE:  
 ALLUMINIO ANODIZZATO  
 MATERIAL:  
 ANODIZED ALUMINUM

**DIMENSIONI - DIMENSIONS**

Ø	A	B	C	D	E	F	G	H	J	K	L	ØM	N	O	P	Q	R
16	1,5	18	26	3,6	4	14	1,5	12,5	41,5	53,5	5	5,5	20	3	-	-	-
25	2,5	27	40	5,5	6	22	2	18	48,5	60	6	5,5	20	4	-	-	-
32	5	36	51	6,5	8	24	4	20	82	91	30	4,5	45	6	20	30	20
40	5	54	71	9	11,5	24	2	20	90	99	25	4,5	45	8,5	30	30	20
50	5	70	80	9	12,5	25	1	25	123	148	35	6,5	45	1	45	30	35
63	5	78	105	11	15	30	2	40	147	172	35	6,5	45	3,5	48	30	35

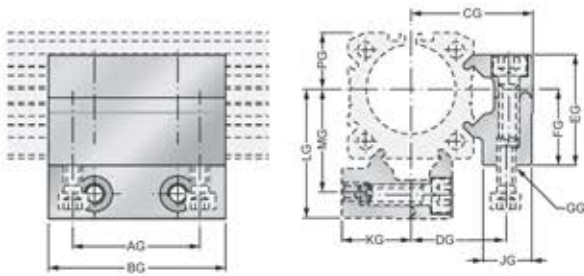
**SUPPORTO INTERMEDIO TIPO C**
**MOBILE MID SECTION SUPPORT C TYPE**

MATERIALE:  
ALLUMINIO ANODIZZATO  
MATERIAL:  
ANODIZED ALUMINUM

**DIMENSIONI - DIMENSIONS**

ø	AG	BG	CG	DG	EG	FG	GG	JG	KG	LG	MG	PG
16	18	30	27,5	18,4	21	15	M4	11,5	13,9	29	19,7	10,8
25	36	50	34,5	27	31,3	22	M5	14	20	36,5	29	16
32	36	50	41,8	34,2	39	30	M6	14	27,6	47	39,5	21,5

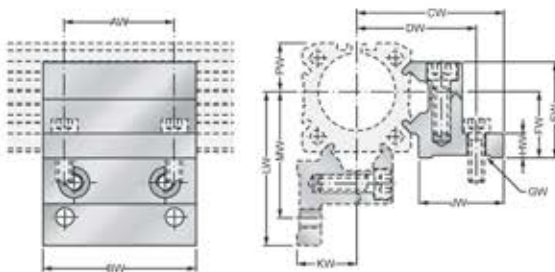
**SUPPORTO INTERMEDIO TIPO CL**
**MOBILE MID SECTION SUPPORT CL TYPE**

MATERIALE:  
ALLUMINIO ANODIZZATO  
MATERIAL:  
ANODIZED ALUMINUM

**DIMENSIONI - DIMENSIONS**

ø	AW	BW	CW	DW	EW	FW	ØGW	HW	JW	KW	LW	MW	PW
16	18	30	37	32,5	21	15	4,5	6	22,4	13,9	38	32,9	10,8
25	36	50	47,5	40	31,3	22	5,5	10	26	20	49,5	42	16
32	36	50	56	47,5	39	30	6,5	10	28,5	27,6	61	52,5	21,5

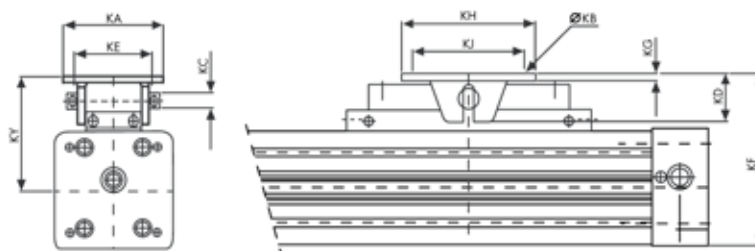
**FLANGIA BASCULANTE**
**FBSS---**
**ARTICULATED CARRIER**

MATERIALE:  
ACCIAIO ZINCATO  
MATERIAL:  
ZINC COATED STEEL

**DIMENSIONI - DIMENSIONS**

Ø	KA	KB	KD	KE	KF	KG	KH	KJ	KY
16	26	M4	10	10	46,5 - 47,5	3	28	20	33
25	38	M5	19	16	71,5 - 73,5	3,5	40	30	51,5
32	62	M6	28	25	94,5 - 96,5	6	60	46	66,5
40	62	M6	28	25	108 - 110	6	60	46	73,5
50	90	9	43,7	70	135 - 150	6,4	120	100	95 - 110
63	90	9	43,7	70	155 - 170	6,4	120	100	102 - 117

 SERIE  
**D**







Realized and distributed by  
**Triveneta automazioni s.r.l.**  
via Carlo Rosselli, 36 - 36061 Bassano del Grappa (VI)  
tel. 0424/505152 - fax 0424/505189

[www.triveneta.it](http://www.triveneta.it) - [www.t3components.com](http://www.t3components.com)  
[amministrazione@triveneta.it](mailto:amministrazione@triveneta.it)  
[sales.manager@triveneta.it](mailto:sales.manager@triveneta.it)  
[info@t3components.com](mailto:info@t3components.com)





**TRIVENETA AUTOMAZIONI s.r.l.**

Tel. 0424 505152 - Fax 0424 505189

[info@t3components.com](mailto:info@t3components.com)

[www.t3components.com](http://www.t3components.com)