

SERIE
CN

2024_LINE_1

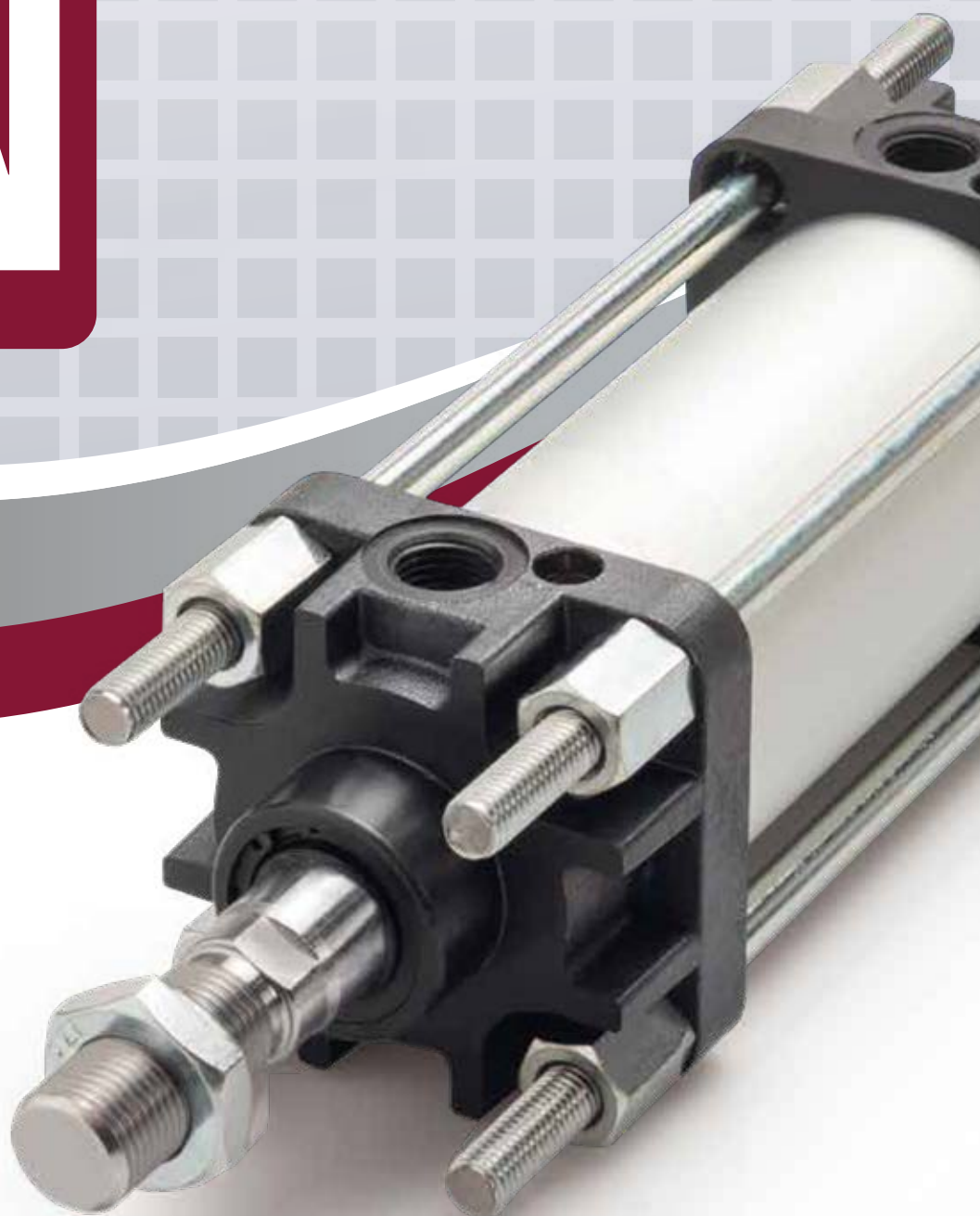

Cilindri CNOMO
CNOMO cylinders



CARATTERISTICHE TECNICHE - TECHNICAL CHARACTERISTICS

Pressione di esercizio <i>Working pressure</i>	1 ÷ 10 bar (doppio effetto - <i>double acting</i>)
Temperatura di esercizio <i>Working temperature</i>	0 ÷ +80°C (-20°C con aria secca - <i>with dry air</i>) versione non magnetica - <i>not magnetic version</i> 0 ÷ +70° C (-10°C con aria secca - <i>with dry air</i>) versione magnetica - <i>magnetic version</i> 0 ÷ +150°C (con guarnizioni per alte temperature - <i>with high temperature seals</i>)
Versioni - Versions	doppio effetto - stelo passante <i>double acting - double rod</i>
Alesaggi - Bores	∅ 32 - 40 - 50 - 63 - 80 - 100 - 125 - 160 - 200
Corse - Strokes	vedere tabelle corse standard - <i>see standard stroke tables</i>
Fluido - Fluid	aria compressa filtrata, non lubrificata - <i>compressed filtered, non lubricated air</i>

CARATTERISTICHE COSTRUTTIVE - CONSTRUCTIVE CHARACTERISTICS

Stelo - Piston rod	acciaio C45 cromato - <i>C45 Chromed steel</i>
Guarnizioni - Seals	NBR
Boccola - Bush	bronzo sinterizzato - <i>sintered bronze</i>
Testate - Covers	alluminio anodizzato - <i>anodized aluminium</i>
Tubo - Tube	alluminio anodizzato - <i>anodized aluminium</i>
Magnete - Magnet	plastroferrite - <i>rubber magnet</i>
Pistone - Piston	monoblocco in NBR - <i>NBR monoblock</i>
Ammortizzo - Cushioning	ottone - <i>brass</i>
Viti - Screws	acciaio zincato - <i>zinc coated steel</i>
Tiranti - Tie rod	acciaio zincato - <i>zinc coated steel</i>
O-ring	NBR

CHIAVE DI CODIFICA

KEY CODE

C		N		D		M		0		5		0		.		1		0		0		.		G		S		.		M	
				ALESAGGIO - BORE (Ø)				CORSA - STROKE (mm)																							
				032-040-050-063-080 100-125-160-200				vedere tabelle corse std see std stroke tables																							
				VERSIONE - VERSION																											
				P stelo passante double rod																											
				VERSIONE - VERSION								GUARNIZIONI - SEALS								OPZIONE - OPTION											
				M magnetico magnetic								guarnizioni standard standard seals				GS				C1 C1CN montata C1CN mounted											
				non magnetico non-magnetic								guarnizione stelo per alte temperature high temperature rod seal				VR				S con tiranti sporgenti with extended tie rod											
				VERSIONE - VERSION								tutte le guarnizioni per alte temperature all seals for high temperature				VA															
				D doppio effetto double acting																											
				SERIE - SERIES																											
				CN cilindro CNOMO CNOMO cylinder																											
												STELO - ROD																			
												femmina female				F															
												maschio male				M															

SERIE
CN

ESECUZIONI A RICHIESTA - ON REQUEST

Filetti speciali (dado non fornito) - Special thread (without rod nut)

Stelo prolungato (WH) - Extended rod (WH)

Corse fuori standard - Special strokes

FORZE TEORICHE DI TRAZIONE (P=6bar)

THEORETICAL FORCES OF TRACTION (P=6bar)

		Ø	032	040	050	063	080	100	125	160	200
CND	SPINTA THRUST	[N]	483	754	1.178	1.870	3.016	4.712	7.363	12.064	18.850
CNDM	TRAZIONE TRACTION	[N]	415	633	990	1.682	2.721	4.418	6.881	11.310	18.096
CNDP	SPINTA THRUST	[N]	415	633	990	1.682	2.721	4.418	6.881	11.310	18.096
CNDMP	TRAZIONE TRACTION	[N]	415	633	990	1.682	2.721	4.418	6.881	11.310	18.096

CILINDRO CNOMO DOPPIO EFFETTO MAGNETICO AMMORTIZZATO

CNOMO CYLINDER DOUBLE ACTING MAGNETIC CUSHIONED

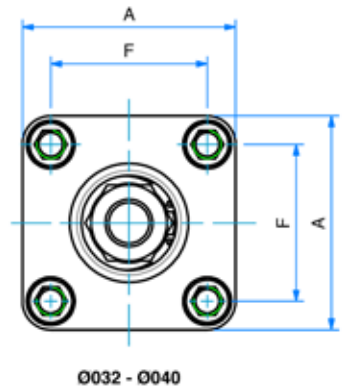
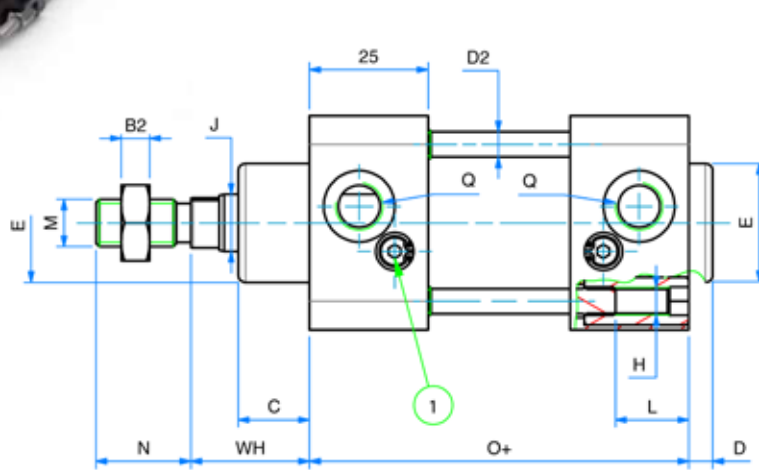
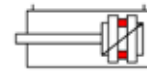

SERIE
CN

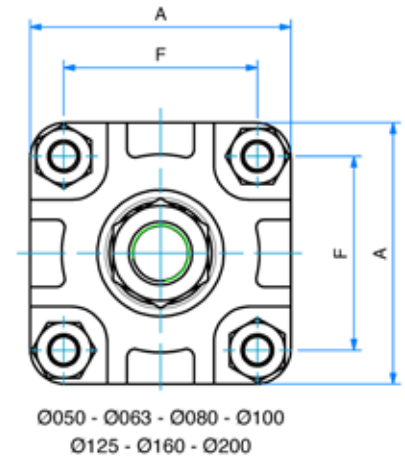
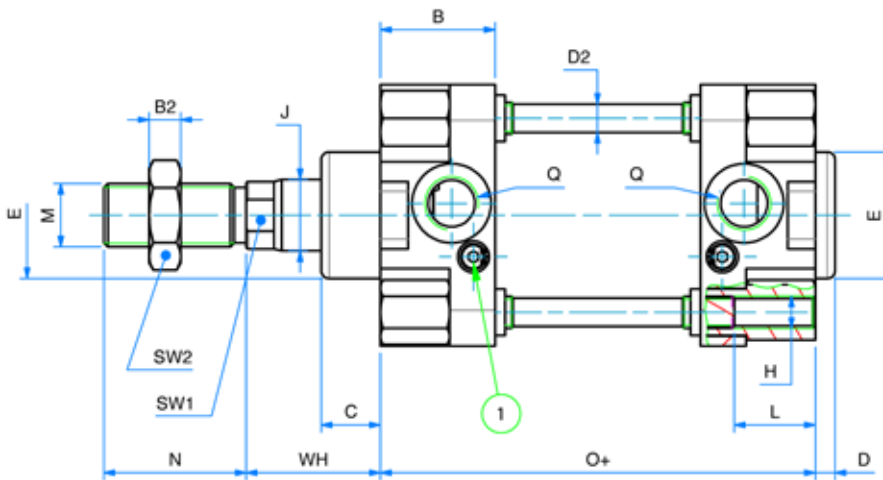

① Vite regolazione ammortizzo - Cushioning adjustment screw

VERSIONE CON TIRANTI SPORGENTI - EXTENDED TIE ROD VERSION

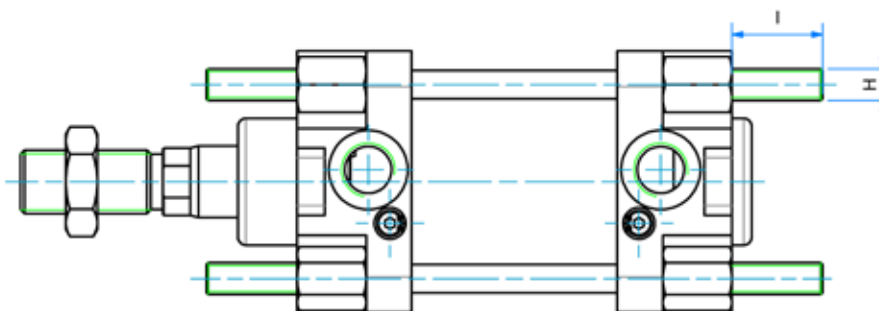

CILINDRO CNOMO DOPPIO EFFETTO MAGNETICO AMMORTIZZATO
CNOMO CYLINDER DOUBLE ACTING MAGNETIC CUSHIONED
DIMENSIONI - DIMENSIONS

Ø	032	040	050	063	080	100	125	160	200
A	45	52	66	75	95	115	140	180	220
B	25	29	29	34	41	44	48,5	60	59
B2	6	8	8	9	9	12	12	14	14
C	15	15	15	20	20	20	20	35	35
D	5	5	5	5	5	5	5	5	5
Ø D2	5,3	5,3	7,15	7,15	9	9	10,8	14,6	14,6
Ø E	25	32	32	45	45	55	55	65	65
F	33	40	49	59	75	90	110	140	175
H	M6	M6	M8	M8	M10	M10	M12	M16	M16
Ø J	12	18	18	22	22	30	30	40	40
L	15,5	15,5	20,5	20,5	23,5	23,5	-	-	-
M	M10	M16x1,5	M16x1,5	M20x1,5	M20x1,5	M27x2	M27x2	M36x2	M36x2
N	20	36	36	46	46	63	63	85	85
O +	80	110	110	125	125	145	145	180	180
Q	G1/8"	G1/4"	G1/4"	G3/8"	G3/8"	G1/2"	G1/2"	G3/4"	G3/4"
SW1	10	15	15	19	19	27	27	36	36
SW2	17	24	24	30	30	41	41	55	55
WH	25	34	34	39	39	47	47	50	50
*	20	21	23	26	32	26	26	32	32

+ = lunghezza corsa - stroke length

* = lunghezza ammortizzo - cushioning length

SERIE
CN

VERSIONE CON TIRANTI SPORGENTI - EXTENDED TIE ROD VERSION

Ø	032	040	050	063	080	100	125	160	200
I	17	17	23	23	28	28	34	42	42

Note: Ø 125 - 160 - 200 tiranti sporgenti di serie

Note: Ø 125 - 160 - 200 extended tie rod as standard

Note: dado stelo compreso nella fornitura

Note: rod nut included in the supply

Ø CORSE STANDARD - STANDARD STROKES

032	25 - 50 - 75 - 100 - 125 - 150 - 200 - 250 - 300 - 350 - 400 - 450 - 500 - 550 - 600 - 650 - 700 - 750 - 800 - 850 - 900 - 950 - 1000
040	25 - 50 - 75 - 100 - 125 - 150 - 200 - 250 - 300 - 350 - 400 - 450 - 500 - 550 - 600 - 650 - 700 - 750 - 800 - 850 - 900 - 950 - 1000
050	25 - 50 - 75 - 100 - 125 - 150 - 200 - 250 - 300 - 350 - 400 - 450 - 500 - 550 - 600 - 650 - 700 - 750 - 800 - 850 - 900 - 950 - 1000
063	25 - 50 - 75 - 100 - 125 - 150 - 200 - 250 - 300 - 350 - 400 - 450 - 500 - 550 - 600 - 650 - 700 - 750 - 800 - 850 - 900 - 950 - 1000
080	25 - 50 - 75 - 100 - 125 - 150 - 200 - 250 - 300 - 350 - 400 - 450 - 500 - 550 - 600 - 650 - 700 - 750 - 800 - 850 - 900 - 950 - 1000
100	25 - 50 - 75 - 100 - 125 - 150 - 200 - 250 - 300 - 350 - 400 - 450 - 500 - 550 - 600 - 650 - 700 - 750 - 800 - 850 - 900 - 950 - 1000
125	25 - 50 - 75 - 100 - 125 - 150 - 200 - 250 - 300 - 350 - 400 - 450 - 500 - 550 - 600 - 650 - 700 - 750 - 800 - 850 - 900 - 950 - 1000

ACCESSORI DI FISSAGGIO CILINDRO CNOMO

CNOMO CYLINDER MOUNTING PARTS

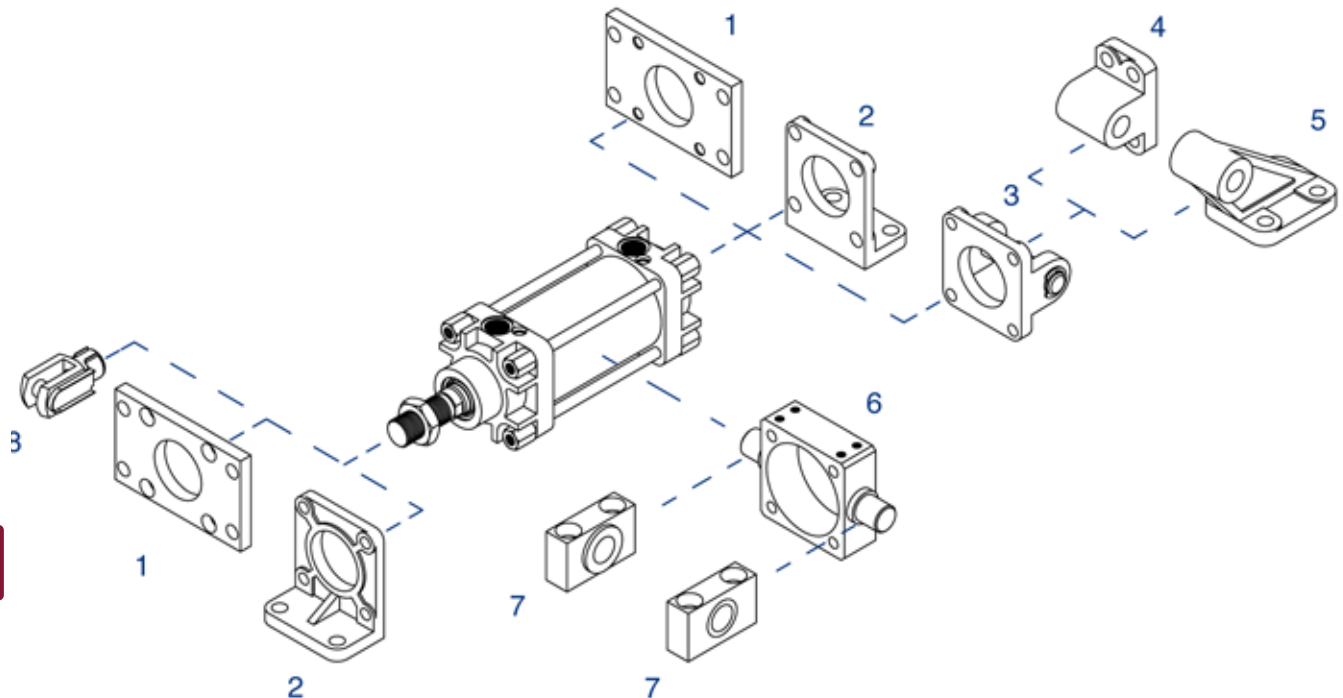

SERIE
CN

POS.	CODE	DESCRIZIONE-DESCRIPTION
1	FCN---	flangia CNOMO - CNOMO flange
2	PACN---	pedino alto CNOMO - CNOMO foot mounting
3	CFCN---P	cerniera femmina CNOMO con perno CNOMO female hinge with pin
4	CMCN---	cerniera maschio CNOMO - CNOMO male hinge
5	ASCN---	articolazione a squadra CNOMO CNOMO square hinge
6	CICN---	cerniera intermedia CNOMO CNOMO intermediate hinge
7	SCI---	supporto cerniera intermedia support for intermediate hinge
8	FC---x---CN	forcella CNOMO con clips CNOMO clevis with lockable pin

Fissaggi forniti con viti - Mounting parts supplied with screws

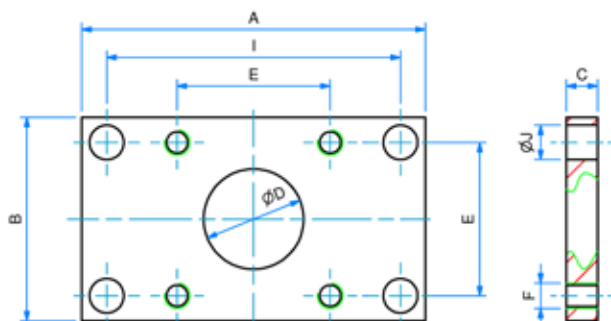
FLANGIA CNOMO
CNOMO FLANGE

LA FORNITURA COMPRENDE:
n° 1 FLANGIA
n° 4 VITI
THE SUPPLY INCLUDES:
n° 1 FLANGE
n° 4 SCREWS

MATERIALE:
ACCIAIO ZINCATO
MATERIAL:
ZINC COATED STEEL

DIMENSIONI - DIMENSIONS

COD.	FCN032	FCN040	FCN050	FCN063	FCN080	FCN100	FCN125	FCN160	FCN200
Ø	32	40	50	63	80	100	125	160	200
A	80	90	110	120	150	170	205	260	300
B	45	52	65	75	95	115	140	180	220
C	8	8	10	10	12	12	16	20	20
ØD	25	32	32	45	45	55	55	65	65
E	33	40	49	59	75	90	110	140	175
F	M6	M6	M8	M8	M10	M10	M12	M16	M16
I	68	78	94	104	130	150	180	228	268
ØJ	9	9	11	11	14	14	18	22	22

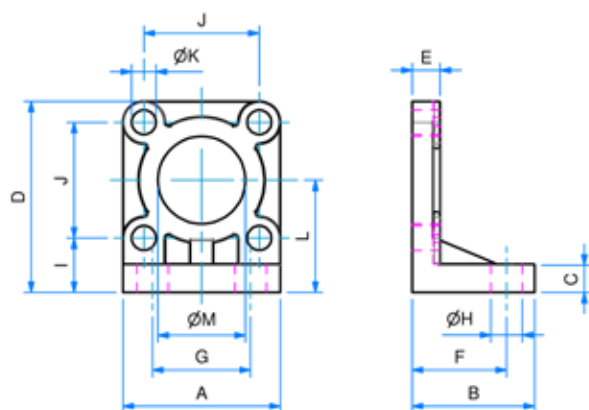
**SERIE
CN**
PIEDINO ALTO CNOMO
CNOMO FOOT MOUNTING

LA FORNITURA COMPRENDE:
n° 1 PIEDINO
n° 4 VITI
THE SUPPLY INCLUDES:
n° 1 FOOT MOUNTING
n° 4 SCREWS

MATERIALE:
ALLUMINIO
MATERIAL:
ALUMINIUM

DIMENSIONI - DIMENSIONS

COD.	PACN032	PACN040	PACN050	PACN063	PACN080	PACN100	PACN125	PACN160	PACN200
Ø	32	40	50	63	80	100	125	160	200
A	45	52	65	75	95	115	140	180	220
B	35	35	43	45	55	55	68	80	90
C	8	8	10	10	12	14	16	20	20
D	54,5	62	77,5	87,5	110,5	130	160	205	245
E	8	8	8	10	12	12	16	20	20
F	27	27	35	35	43	43	52	62	62
G	28	36	45	55	70	90	100	130	170
ØH	9	9	11	11	14	14	18	22	22
I	15,5	16	20,5	20,5	25,5	28	35	45	47,5
J	33	40	49	59	75	90	110	140	175
ØK	7	7	9	9	11	11	14	18	18
L	32	36	45	50	63	73	90	115	135
ØM	25	32	32	45	45	55	55	65	65

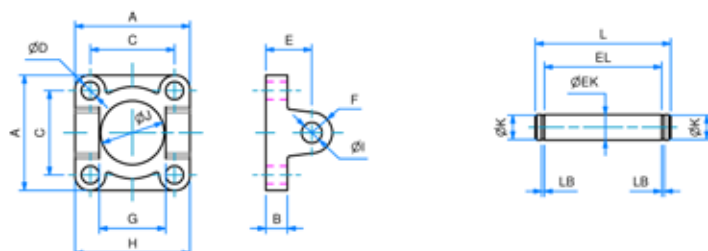
CERNIERA FEMMINA CNOMO CON PERNO
CNOMO FEMALE HINGE WITH PIN

LA FORNITURA COMPRENDE:
 n° 1 CERNIERA FEMMINA
 n° 1 PERNO
 n° 2 SEEGER
 n° 4 VITI
 THE SUPPLY INCLUDES:
 n° 1 FEMALE HINGE
 n° 1 PIN
 n° 2 RETAINING RING
 n° 4 SCREWS

MATERIALE:
 ALLUMINIO
 ACCIAIO ZINCATO
 MATERIAL:
 ALUMINIUM
 ZINC COATED STEEL

DIMENSIONI - DIMENSIONS

COD.	CFCN032P	CFCN040P	CFCN050P	CFCN063P	CFCN080P	CFCN100P	CFCN125P	CFCN160P	CFCN200P
Ø	32	40	50	63	80	100	125	160	200
A	45	52	65	75	95	115	140	180	220
B	8	8	10	10	12	12	16	20	20
C	33	40	49	59	75	90	110	140	175
ØD	7	7	9	9	11	11	14	18	18
E	18	24	26	30	32	37	41	55	55
F	8	12	13	17	17	21	21	30	30
G	26	33	33	47	47	57	57	72	72
H	45	52	65	75	95	115	140	180	220
ØI	8	12	12	16	16	20	20	25	25
ØJ	25	32	32	45	45	55	55	65	65
ØEK	8	12	12	16	16	20	20	25	25
L	52	61	74	85	105	126	151	191	233
EL	46	53	66	76	96	116	141	181	223
ØK	5	8	8	12	12	15	15	19	19
LB	0,8	1,2	1,2	1,4	1,4	1,6	1,6	2	2

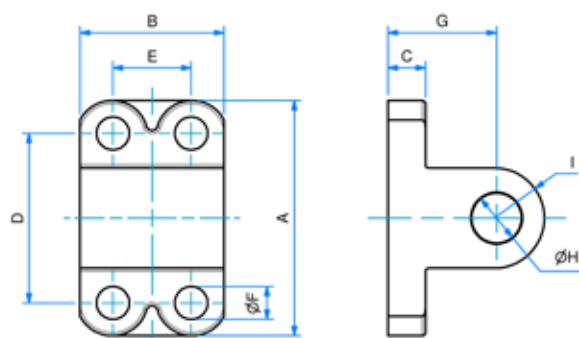
**SERIE
CN**
CERNIERA MASCHIO CNOMO
CNOMO MALE HINGE

LA FORNITURA COMPRENDE:
 n° 1 CERNIERA MASCHIO
 THE SUPPLY INCLUDES:
 n° 1 MALE HINGE

MATERIALE:
 CORPO IN ALLUMINIO
 BOCCOLA IN ACCIAIO E PTFE
 MATERIAL:
 BODY IN ALUMINIUM
 BUSH IN STEEL AND PTFE

DIMENSIONI - DIMENSIONS

COD.	CMCN032	CMCN032.040	CMCN063.080	CMCN100.125	CMCN160.200
Ø	32	40-50	63-80	100-125	160-200
A	40	52	75	115	180
B	25	32	46	56	71
C	8	10	12	16	20
D	28	38	54	90	150
E	-	16	25	32	43
ØF	7	9	11	14	18
G	18	26	34	41	55
ØH	8	12	16	20	25
I	8,5	11,5	16	23,5	26

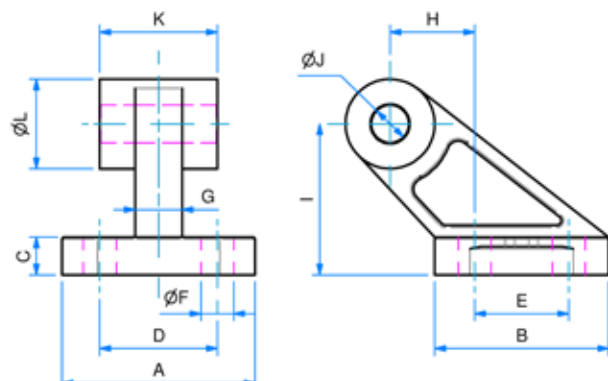
ARTICOLAZIONE A SQUADRA CNOMO
CNOMO SQUARE HINGE

LA FORNITURA COMPRENDE:
n°1 ARTICOLAZIONE A SQUADRA
THE SUPPLY INCLUDES:
n°1 SQUARE HINGE

MATERIALE:
ALLUMINIO
MATERIAL:
ALUMINIUM

DIMENSIONI - DIMENSIONS

COD.	ASCN032	ASCN032.040	ASCN063.080	ASCN100.125	ASCN160.200
Ø	32	40-50	63-80	100-125	160-200
A	41	52	63	80	110
B	37	54	75	103	154
C	8	10	12	16	20
D	25	32	40	50	63
E	20	32	50	70	110
ØF	7	9	11	14	18
G	10	12	15	22	25
H	18	25	32	40	50
I	32	45	63	90	140
ØJ	8	12	16	20	25
K	25	32	46	56	71
ØL	19	26	33	44	53

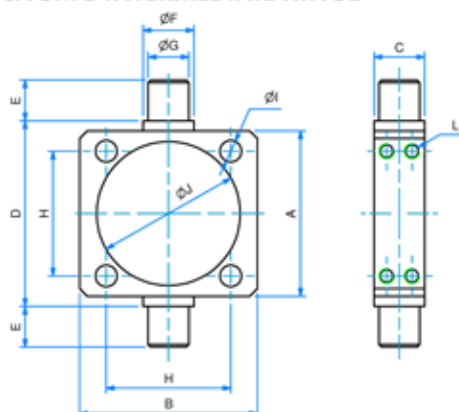
CERNIERA INTERMEDIA CNOMO
CNOMO INTERMEDIATE HINGE

LA FORNITURA COMPRENDE:
n°1 CERNIERA INTERMEDIA
THE SUPPLY INCLUDES:
n°1 INTERMEDIATE HINGE

MATERIALE:
ACCIAIO ZINCATO
MATERIAL:
ZINC COATED STEEL

DIMENSIONI - DIMENSIONS

COD.	CICN032	CICN040	CICN050	CICN063	CICN080	CICN100	CICN125	CICN160	CICN200
Ø	32	40	50	63	80	100	125	160	200
A	45	55	65	80	100	124	152	190	240
B	50	60	70	80	100	130	150	200	250
C	20	20	20	30	30	30	30	40	40
D	50	63	73	90	108	131	159	198	248
E	12	16	16	20	20	25	25	32	32
ØF	15	20	20	25	25	30	30	40	40
ØG	12	16	16	20	20	25	25	32	32
ØI	6,25	6,25	8,5	8,5	10,5	10,5	12,5	16,5	16,5
ØJ	37,5	46,5	56,5	69,5	87,5	107,5	133,5	172,5	213
L	M5	M5	M6	M6	M8	M8	M10	M12	M12

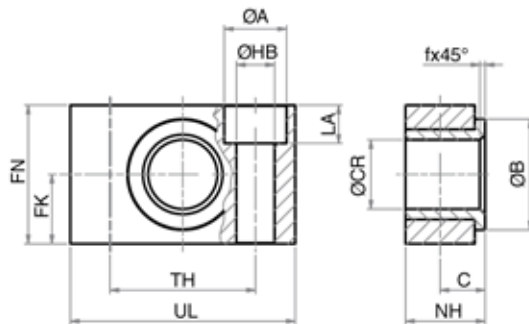
SUPPORTO CERNIERA INTERMEDIA
SUPPORT FOR INTERMEDIATE HINGE

LA FORNITURA COMPRENDE:
 N° 1 SUPPORTO
 N° 2 VITI
 THE SUPPLY INCLUDES:
 n° 1 SUPPORT
 n° 2 SCREWS

MATERIALE:
 CORPO IN ALLUMINIO
 BOCCOLA IN BRONZO
 MATERIAL:
 BODY IN ALUMINIUM
 BUSH IN BRONZE

DIMENSIONI - DIMENSIONS

COD.	SCI032	SCI040.050	SCI063.080	SCI100.125	SCI160.200
ø	32	40-50	63-80	100-125	160-200
C	10,5	12	13	16	22,5
FK	15	18	20	25	30
FN	30	36	40	50	60
f	1	1,6	1,6	2	2,5
LA	7	9	11	13	17
NH	18	21	23	28,5	40
ø A	11	15	18	20	26
ø B	22	28	32	39	45
ø CR	12	16	20	25	32
ø HB	6,6	9	11	14	18
TH	32	36	42	50	60
UL	46	55	65	75	92

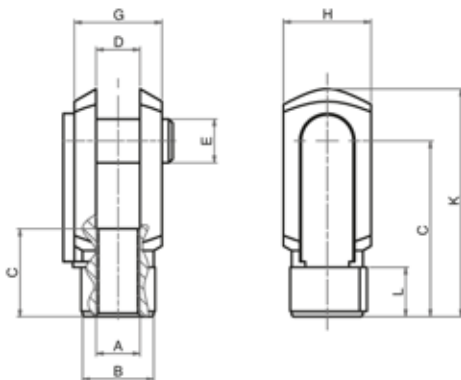
**SERIE
CN**
FORCELLA CNOMO CON CLIPS
FC---X---CN
CNOMO CLEVIS WITH LOCKABLE PIN

LA FORNITURA COMPRENDE:
 n° 1 FORCELLA
 n° 1 CLIPS
 THE SUPPLY INCLUDES:
 n° 1 FORK
 n° 1 LOCKABLE PIN

MATERIALE:
 ACCIAIO ZINCATO
 MATERIAL:
 ZINC COATED STEEL

DIMENSIONI - DIMENSIONS

COD.	FC10X1,5CN	FC16X1,5CN	FC20X1,5CN	FC27X2CN	FC36X2CN
A	M10x1,5	M16x1,5	M20x1,5	M27x2	M36x2
B	18	26	34	42	50
C	36	51	63	85	115
D	11	18	22	30	40
E	8	12	16	20	25
G	22	36	45	63	80
H	22	26	34	42	50
J	20	26	30	45	75
K	45	64	80	105	140
L	14	17	18,5	30	45



Realized and distributed by
Triveneta automazioni s.r.l.
via Carlo Rosselli, 36 - 36061 Bassano del Grappa (VI)
tel. 0424/505152 - fax 0424/505189

www.triveneta.it - www.t3components.com
amministrazione@triveneta.it
sales.manager@triveneta.it
info@t3components.com





TRIVENETA AUTOMAZIONI s.r.l.

Tel. 0424 505152 - Fax 0424 505189

info@t3components.com

www.t3components.com