

# MINICILINDRI ISO 6432 Ø8-25 ISO 6432 MINI-CYLINDERS Ø8-25



Cilindri costruiti a norma ISO6432. Altamente resistenti con testate cianfrinate. Fornito con dado testata e dado sullo stelo. Esecuzione magnetica e non, ammortizzata e non. Disponibile anche a semplice effetto. Vasta scelta di accessori di fissaggio. A richiesta in conformità alla Direttiva ATEX.

ISO 6432 cylinders  
Highly resistant with crimped covers. Supplied with cover and piston rod nuts. Magnetic and non-magnetic version, with or without adjustable cushioning. Available also single-acting. Wide range of mountings. On request in accordance with ATEX Directive.

## VERSIONE VERSION

CSE		CSET	
CSEM		CSEMT	
CDE		CDEP	
CDEM		CDEMP	
CDEA		CDEAP	
CDEMA		CDEMAP	

## CHIAVI DI CODIFICA CYLINDERS KEY CODE

## INFORMAZIONI TECNICHE TECHNICAL INFORMATION

Testate Covers	Alluminio anodizzato Anodized Aluminium
Tubo Tube	Acciaio inox AISI304 AISI304 Stainless steel
Pistone Piston	Ottone Brass
Guarnizioni Seals	Ø8-10-12 poliuretano - NBR Ø16-20-25 poliuretano Ø8-10-12 polyurethane - NBR Ø16-20-25 polyurethane
Boccola guida Guiding bush	Bronzo sinterizzato Sintered bronze
Stelo Piston rod	Acciaio inox AISI303 AISI303 Stainless steel
Pressione MAX MAX pressure	10 bar
Temperatura di impiego Working temperature	Ø8-10-12 -20°C +80°C con aria secca Ø16-20-25 -35°C +80°C con aria secca Ø8-10-12 -20°C +80°C with dry air Ø16-20-25 -35°C +80°C with dry air
Fluido Working fluid	Aria compressa filtrata e lubrificata e non Filtered and lubricated or not compressed air

Versione Version	Diametro Diameter	Corsa Stroke	Tipo costruttivo Design Type	Guarnizioni Seals
CSE	08	0...1000	- Versione standard Standard version	- Standard
CSEM	10		RR Versione corta, alimentazione radiale Short version, radial inlet	V Guarnizioni FKM FKM seals
CDE	12		RA Versione corta, alimentazione assiale Short version, axial inlet	VG Guarnizione stelo FKM FKM rod seal
CDEM	16		ES Versione antirrotazione a stelo esagonale Non rotating version with hexagonal piston rod	
CDEA	20			
CDEMA	25			
CSET				
CSEMT				
CDEP				
CDEMP				
CDEAP				
CDEMAP				

## CORSE STANDARD CILINDRO DOPPIO EFFETTO STANDARD STROKES DOUBLE ACTING CYLINDER

Ø (mm)	Corse standard (mm) Standard strokes (mm)													
8	10	25	40	50	80	100								
10	10	25	40	50	80	100								
12	10	25	40	50	80	100	125	160	200					
16	10	25	40	50	80	100	125	160	200					
20	10	25	40	50	80	100	125	160	200	250	300	320		
25	10	25	40	50	80	100	125	160	200	250	300	320	400	500

## CORSE STANDARD CILINDRO SEMPLICE EFFETTO STANDARD STROKES SINGLE ACTING CYLINDER

Ø (mm)	Corse standard (mm) Standard strokes (mm)		
8	10	25	50
10	10	25	50
12	10	25	50
16	10	25	50
20	10	25	50
25	10	25	50







## FORZE TEORICHE A 6 BAR THEORETICAL FORCES AT 6 BAR

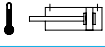

Ø (mm)	Forza di spinta (N) Thrust force (N)	Forza di trazione (N) Traction force (N)
8	30	23
10	47	40
12	68	51
16	121	104
20	189	158
25	295	247

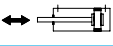
## FORZE TEORICHE DELLE MOLLE THEORETICAL SPRING FORCES

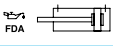
Ø (mm)	Molla anteriore Front spring						Molla posteriore Rear spring					
	Corsa Stroke 10		Corsa Stroke 25		Corsa Stroke 50		Corsa Stroke 10		Corsa Stroke 25		Corsa Stroke 50	
	F1(N)	F2(N)	F1(N)	F2(N)	F1(N)	F2(N)	F1(N)	F2(N)	F1(N)	F2(N)	F1(N)	F2(N)
8	4.1	4.6	3.4	4.6	2.2	4.6	5.5	6	4.8	6	3.6	6
10	4.1	4.6	3.4	4.6	2.2	4.6	5	6.2	3.3	6.2	-	-
12	5.6	6	5.5	6	4.1	6	13	14.2	11.3	14.2	8.5	14.2
16	19.2	21.5	15.7	21.5	9.8	21.5	19	20.7	16.3	20.7	12	20.7
20	20.4	22.5	17.3	22.5	11.7	22.5	57.2	61.5	50.7	61.5	39.8	61.5
25	17.5	18.8	15.6	18.8	12.4	18.8	28.5	30.6	25.3	30.6	19.8	30.6

## VARIANTI VARIANTS

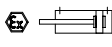
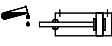
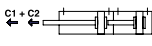
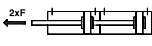
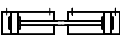
Simbolo Symbol	Caratteristiche Features
	Resistente alle alte temperature -10...+150°C Heat-resistant -10...+150°C
	Resistente alle basse temperature -40...+80°C Low temperature resistant -40...+80°C
	Stelo prolungato Piston rod extension
	Basso attrito Low friction
	Stelo in acciaio inox Stainless steel piston rod
	Lubrificazione FDA FDA lubrication
	Filettature e steli su richiesta Custom made thread or piston rod

Simbolo Symbol	Caratteristiche Features
	Certificazione ATEX ATEX certification
	Guarnizione stelo ad elevata resistenza chimica Rod seal with increased chemical resistance
	Configurazione tandem a più posizioni Multi position configuration
	Configurazione tandem a doppia spinta Double thrust tandem configuration
	Configurazione tandem contrapposti anteriore Front opposed tandem configuration
	Configurazione tandem contrapposti posteriore Rear opposed tandem configuration

# MINICILINDRI ISO 6432 Ø8-25 ISO 6432 MINI-CYLINDERS Ø8-25

SEMPLICE EFFETTO  
SINGLE ACTING

CSEØ/...

CSEMØ/...

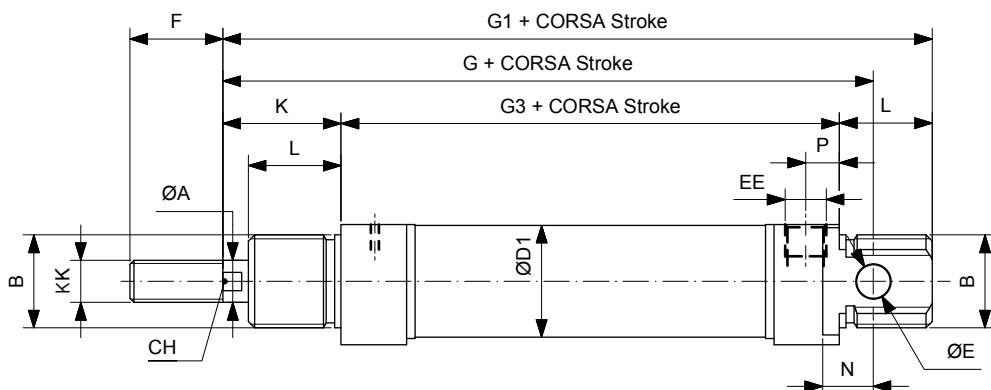
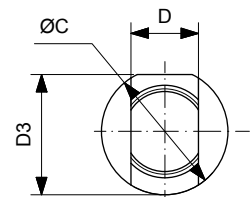

Ø	ØA	B	ØC	CH	D	ØD1	D3	ØE	EE	F	G	G1	G3	K	KK	L	N	P
8	4	M12x1.25	16	/	8	9.27	15	4	M5	12	64	74	46	16	M4x0.7	12	6	5
10	4	M12x1.25	16	/	8	11.27	15	4	M5	12	64	74	46	16	M4x0.7	12	6	5
12	6	M16x1.5	19	5	12	13.27	18	6	M5	16	75	88	48	22	M6x1	18	9	5
16	6	M16x1.5	19	5	12	17.27	18	6	M5	16	82	93	53	22	M6x1	18	9	4.5
20	8	M22x1.5	27	7	16	21.27	25.5	8	1/8"G	20	95	111	67	24	M8x1.25	20	12	8
25	10	M22x1.5	30	9	16	26.5	28.5	8	1/8"G	22	104	118	68	28	M10x1.25	22	12	8

SEMPLICE EFFETTO MOLLA POSTERIORE  
SINGLE ACTING REAR SPRING

CSETØ/...

CSEMTØ/...

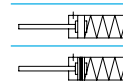
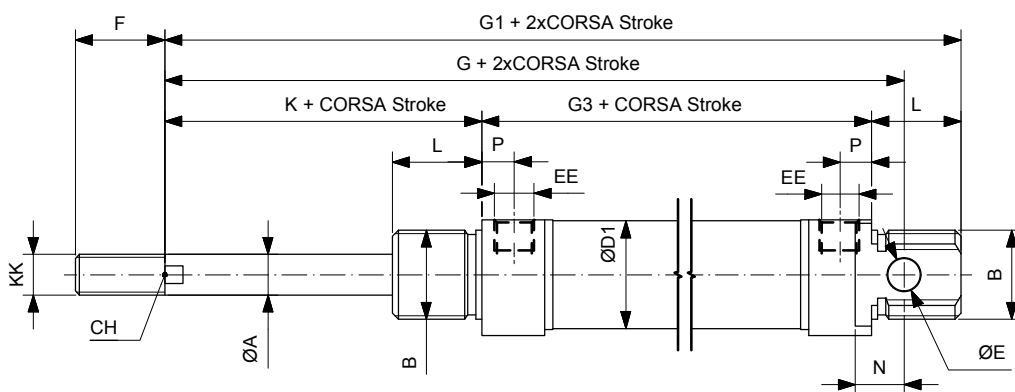
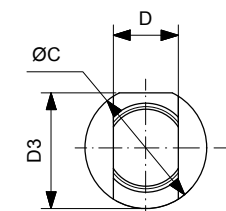

Ø	ØA	B	ØC	CH	D	ØD1	D3	ØE	EE	F	G	G1	G3	K	KK	L	N	P
8	4	M12x1.25	16	/	8	9.27	15	4	M5	12	82	92	64	16	M4x0.7	12	6	5
10	4	M12x1.25	16	/	8	11.27	15	4	M5	12	89.5	99.5	71.5	16	M4x0.7	12	6	5
12	6	M16x1.5	19	5	12	13.27	18	6	M5	16	97.5	110.5	70.5	22	M6x1	18	9	5
16	6	M16x1.5	19	5	12	17.27	18	6	M5	16	111	122	82	22	M6x1	18	9	4.5
20	8	M22x1.5	27	7	16	21.27	25.5	8	1/8"G	20	126.5	142.5	98.5	24	M8x1.25	20	12	8
25	10	M22x1.5	30	9	16	26.5	28.5	8	1/8"G	22	135.5	149.5	99.5	28	M10x1.25	22	12	8

**DOPPIO EFFETTO**  
**DOUBLE ACTING**

**CDEØ/...**

**CDEMØ/...**

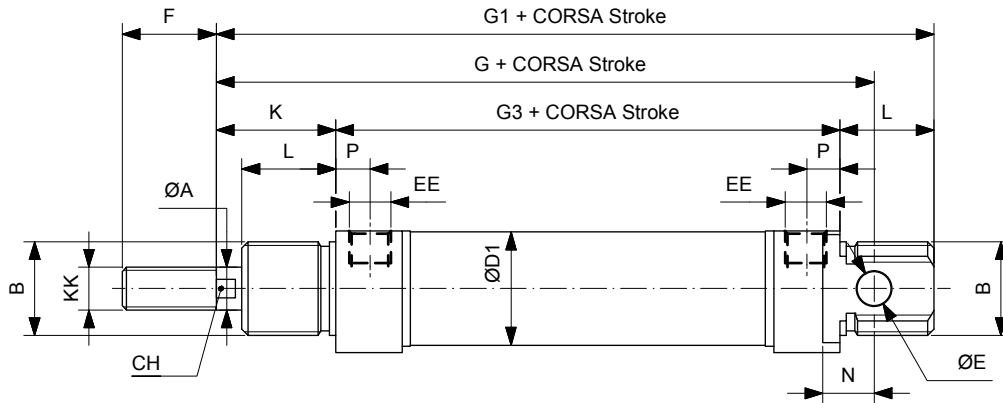
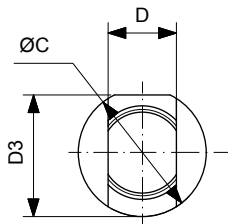

Ø	ØA	B	ØC	CH	D	ØD1	D3	ØE	EE	F	G	G1	G3	K	KK	L	N	P
8	4	M12x1.25	16	/	8	9.27	15	4	M5	12	64	74	46	16	M4x0.7	12	6	5
10	4	M12x1.25	16	/	8	11.27	15	4	M5	12	64	74	46	16	M4x0.7	12	6	5
12	6	M16x1.5	19	5	12	13.27	18	6	M5	16	75	88	48	22	M6x1	18	9	5
16	6	M16x1.5	19	5	12	17.27	18	6	M5	16	82	93	53	22	M6x1	18	9	4.5
20	8	M22x1.5	27	7	16	21.27	25.5	8	1/8"G	20	95	111	67	24	M8x1.25	20	12	8
25	10	M22x1.5	30	9	16	26.5	28.5	8	1/8"G	22	104	118	68	28	M10x1.25	22	12	8

**DOPPIO EFFETTO PASSANTE**  
**DOUBLE ACTING THROUGH PISTON ROD**

**CDEPØ/...**

**CDEMPØ/...**

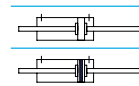
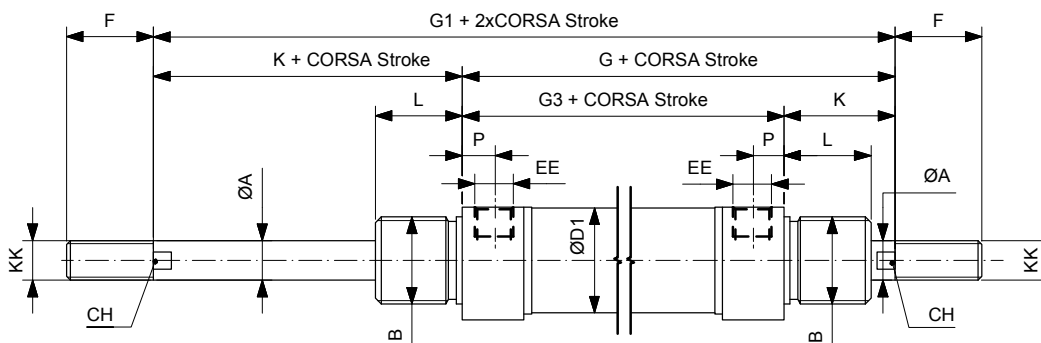
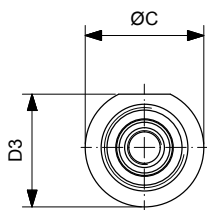

Ø	ØA	B	ØC	CH	ØD1	D3	EE	F	G	G1	G3	K	KK	L	P
8	4	M12x1.25	16	/	9.27	15	M5	12	62	78	46	16	M4x0.7	12	5
10	4	M12x1.25	16	/	11.27	15	M5	12	62	78	46	16	M4x0.7	12	5
12	6	M16x1.5	19	5	13.27	18	M5	16	70	92	48	22	M6x1	18	5
16	6	M16x1.5	19	5	17.27	18	M5	16	75	97	53	22	M6x1	18	4.5
20	8	M22x1.5	27	7	21.27	25.5	1/8"G	20	91	115	67	24	M8x1.25	20	8
25	10	M22x1.5	30	9	26.5	28.5	1/8"G	22	96	124	68	28	M10x1.25	22	8

Ø8-10-12 disponibili solo non magnetici  
Ø8-10-12 only available without magnet

# MINICILINDRI ISO 6432 Ø8-25 ISO 6432 MINI-CYLINDERS Ø8-25

**DOPPIO EFFETTO AMMORTIZZATO**  
DOUBLE ACTING CUSHIONED

CDEAØ/...

CDEMAØ/...

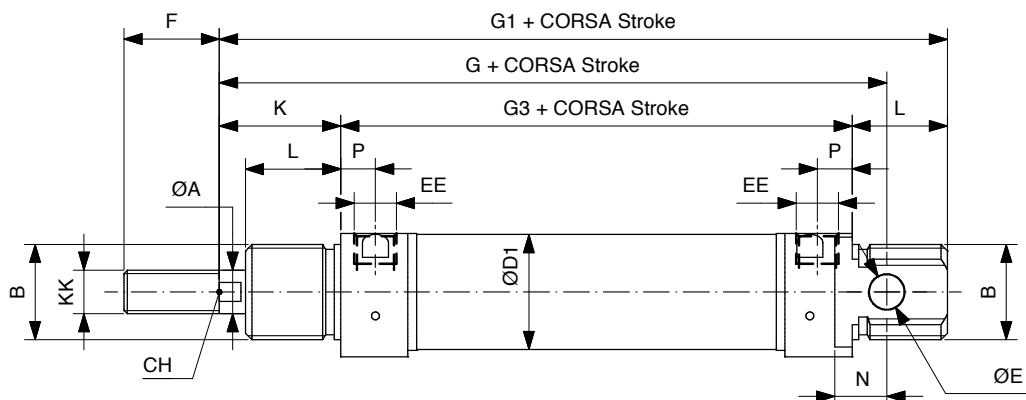
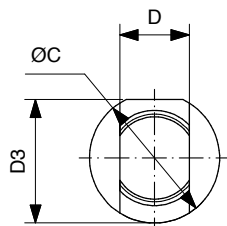

Ø	ØA	B	ØC	CH	D	ØD1	D3	ØE	EE	F	G	G1	G3	K	KK	L	N	P
16	6	M16x1.5	21	5	12	17.27	20	6	M5	16	82	93	55	22	M6x1	17	9	5.5
20	8	M22x1.5	27	7	16	21.27	25.5	8	1/8"G	20	95	111	67	24	M8x1.25	20	12	8
25	10	M22x1.5	30	9	16	26.5	28.5	8	1/8"G	22	104	118	68	28	M10x1.25	22	12	8

**DOPPIO EFFETTO AMMORTIZZATO PASSANTE**  
DOUBLE ACTING CUSHIONED THROUGH PISTON ROD

CDEAPØ/...

CDEMAPØ/...

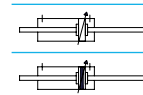
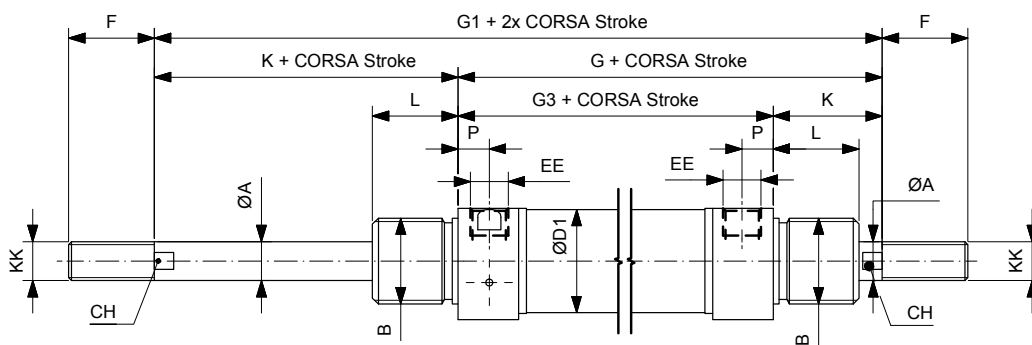
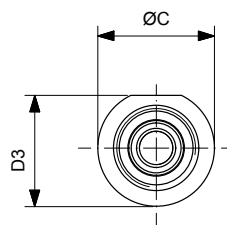

Ø	ØA	B	ØC	CH	ØD1	D3	EE	F	G	G1	G3	K	KK	L	P
16	6	M16x1.5	21	5	17.27	20	M5	16	76	97	55	22	M6x1	17	5.5
20	8	M22x1.5	27	7	21.27	25.5	1/8"G	20	91	115	67	24	M8x1.25	20	8
25	10	M22x1.5	30	9	26.5	28.5	1/8"G	22	96	124	68	28	M10x1.25	22	8

**SERIE CORTA RA SEMPLICE EFFETTO**  
**SHORT SERIES RA SINGLE ACTING**

**CSEØ/...RA**

**CSEMØ/...RA**

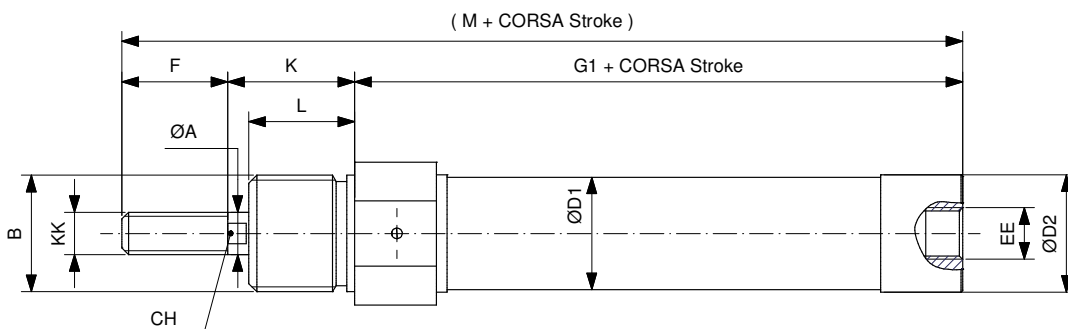
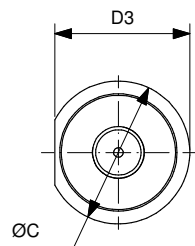

Ø	ØA	B	ØC	CH	ØD1	ØD2	D3	EE	F	G1	K	KK	L	M
16	6	M16x1.5	19	5	17.27	17.2	18	M5	16	52	22	M6x1	18	90
20	8	M22x1.5	27	7	21.27	22.2	25.5	1/8"G	20	65	24	M8x1.25	20	109
25	10	M22x1.5	30	9	26.5	27	28.5	1/8"G	22	66	28	M10x1.25	22	116

**SERIE CORTA RR SEMPLICE EFFETTO**  
**SHORT SERIES RR SINGLE ACTING**

**CSEØ/...RR**

**CSEMØ/...RR**

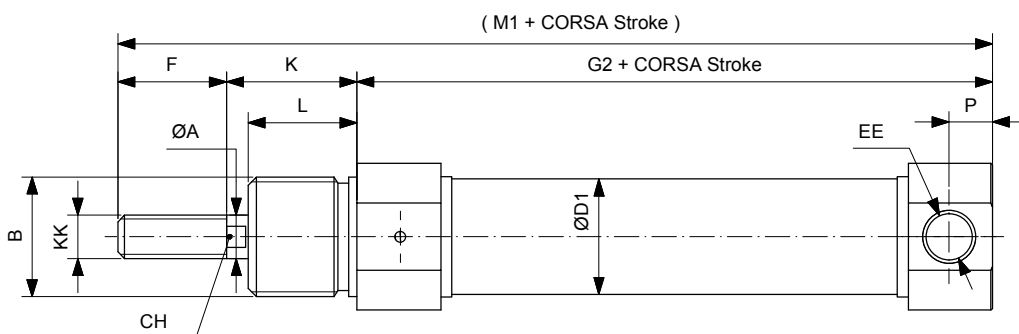
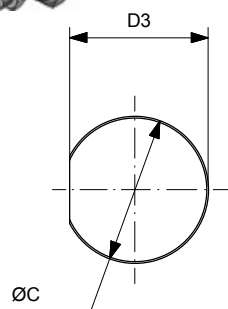

Ø	ØA	B	ØC	CH	ØD1	D3	EE	F	G2	K	KK	L	M1	P
16	6	M16x1.5	19	5	17.27	18	M5	16	52.5	22	M6x1	18	90.5	4.5
20	8	M22x1.5	27	7	21.27	25.5	1/8"G	20	67	24	M8x1.25	20	111	8
25	10	M22x1.5	30	9	26.5	28.5	1/8"G	22	68	28	M10x1.25	22	118	8

# MINICILINDRI ISO 6432 Ø8-25 ISO 6432 MINI-CYLINDERS Ø8-25

## SERIE CORTA RA DOPPIO EFFETTO SHORT SERIES RA DOUBLE ACTING

CDEØ/...RA

CDEMØ/...RA

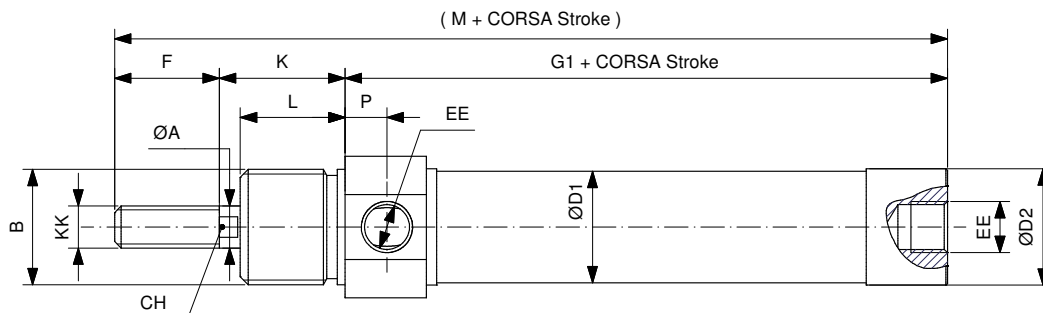
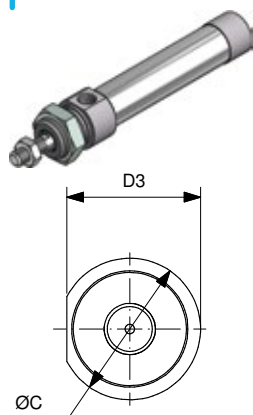

Ø	ØA	B	ØC	CH	ØD1	ØD2	D3	EE	F	G1	K	KK	L	M	P
16	6	M16x1.5	19	5	17.27	17.2	18	M5	16	52	22	M6x1	18	90	4.5
20	8	M22x1.5	27	7	21.27	22.2	25.5	1/8"G	20	65	24	M8x1.25	20	109	8
25	10	M22x1.5	30	9	26.5	27	28.5	1/8"G	22	66	28	M10x1.25	22	116	8

## SERIE CORTA RR DOPPIO EFFETTO SHORT SERIES RR DOUBLE ACTING

CDEØ/...RR

CDEMØ/...RR

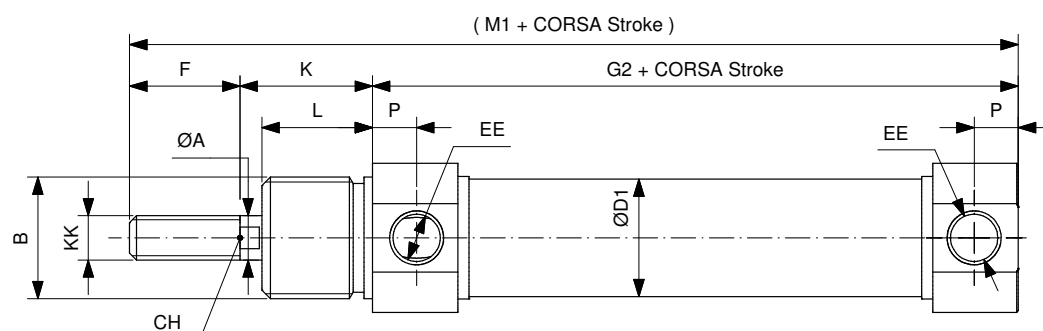
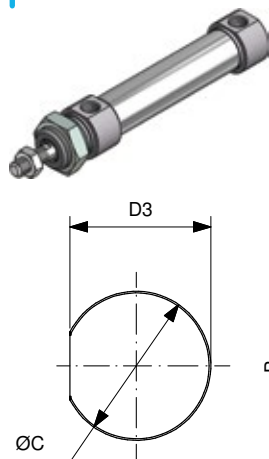

Ø	ØA	B	ØC	CH	ØD1	D3	EE	F	G2	K	KK	L	M1	P
16	6	M16x1.5	19	5	17.27	18	M5	16	52.5	22	M6x1	18	90.5	4.5
20	8	M22x1.5	27	7	21.27	25.5	1/8"G	20	67	24	M8x1.25	20	111	8
25	10	M22x1.5	30	9	26.5	28.5	1/8"G	22	68	28	M10x1.25	22	118	8

**DOPPIO EFFETTO ANTIROTAZIONE ESAGONALE**  
**DOUBLE ACTING NON-ROTATING HEXAGONAL**

CDEØ/...ES

CDEMØ/...ES

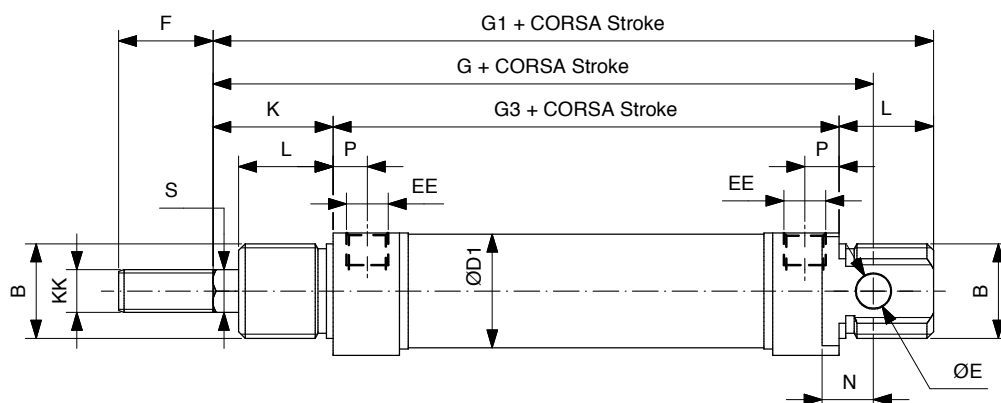
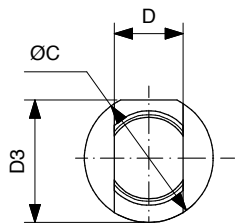

Ø	B	ØC	D	ØD1	D3	ØE	EE	F	G	G1	G3	K	KK	L	N	P	S
16	M16x1.5	19	12	17.27	18	6	M5	16	82	93	53	22	M6x1	18	9	4.5	6
20	M22x1.5	27	16	21.27	25.5	8	1/8"G	20	95	111	67	24	M8x1.25	20	12	8	8
25	M22x1.5	30	16	26.5	28.5	8	1/8"G	22	104	118	68	28	M10x1.25	22	12	8	10

**ACCESSORI DI FISSAGGIO**  
**MOUNTING ACCESSORIES**

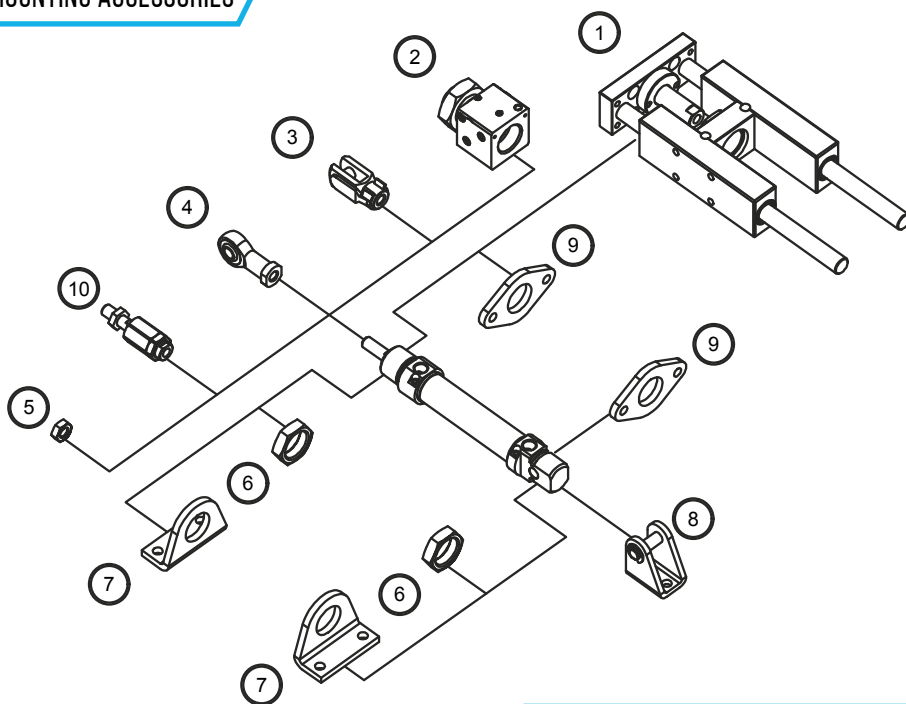

	Descrizione Description	Acciaio Steel version	Acciaio inox Stainless steel
1	Unità di guida / Guide unit	122	-
2	Bloccastelo / Rod lock	126	-
3	Forcella / Clevis	131	147
4	Testa a snodo / Rod end	132	148
5	Dado per stelo / Piston rod nut	130	146
6	Dado testata / Cover nut	130	146
7	Piedino / Foot (MS3)	133	149
8	Cerniera / Hinge (MP3)	133	148
9	Flangia / Flange (MF8)	134	149
10	Giunto autoallineante / Self-aligning joint	131	-