

CILINDRI COMPATTI Ø125-200 COMPACT CYLINDERS Ø125-200

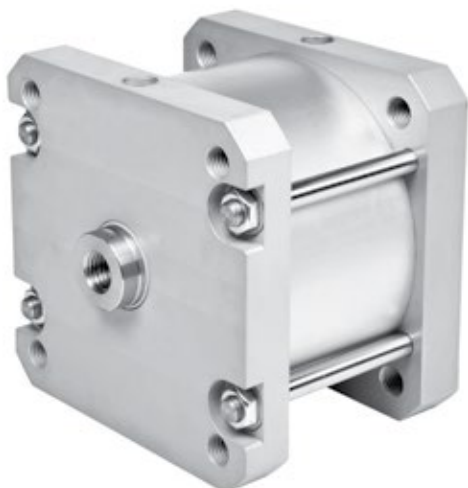

Cilindri compatti disponibili in versione magnetica o non, a stelo singolo o passante, anti rotazione o non.
 Compatibile con la gamma di accessori ISO 15552.
 Su richiesta sono fornibili in varie esecuzioni speciali.

Compact cylinders available with magnet or not, single or through piston rod, non-rotating or not.
 Compatible with ISO 15552 mounting accessories.
 Special versions are available.

VERSIONE VERSION

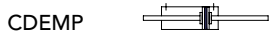
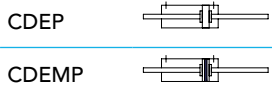
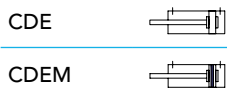

INFORMAZIONI TECNICHE TECHNICAL INFORMATION

Testate Covers	Alluminio anodizzato Anodized aluminium
Tubo Tube	Alluminio anodizzato Anodized aluminium
Guarnizioni Seals	Poliuretano - NBR Polyurethane - NBR
Boccola guida Guiding bush	Ø125 Bronzo sinterizzato; Ø160-200 Acciaio-PTFE Ø125 Sintered bronze; Ø160-200 Steel-PTFE
Stelo Piston rod	Acciaio cromato Chromium coated steel
Tiranti Tie rods	Acciaio Steel
Pressione MAX MAX pressure	10 bar
Temperatura di impiego Working temperature	-20°C +80°C con aria secca -20°C +80°C with dry air
Fluido Working fluid	Aria compressa filtrata e lubrificata e non Filtered and lubricated or not compressed air

CHIAVI DI CODIFICA CYLINDERS KEY CODE

Versione Version		Diametro Diameter	Corsa Stroke	Tipo costruttivo Design Type	Filettatura stelo Piston rod thread	Guarnizioni Seals
CDE	Doppio effetto non magnetico Double acting non magnetic	125	0...2700	KN Standard	F Filettatura femmina Female thread	- Standard
CDEM	Doppio effetto magnetico Double acting magnetic	160			M Filettatura maschio Male thread	V Guarnizioni FKM FKM seals
CDEP	Doppio effetto stelo passante non magnetico Double acting through rod non magnetic	200				VG Guarnizione stelo FKM FKM rod seal
CDEMP	Doppio effetto stelo passante magnetico Double acting through rod magnetic					









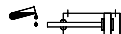

CORSE STANDARD STANDARD STROKES

Ø (mm)	Corse standard (mm) Standard strokes (mm)														
125	5	10	15	20	25	40	50	80	100	125	160	200	250	300	320
160	5	10	15	20	25	40	50	80	100	125	160	200	250	300	320
200	5	10	15	20	25	40	50	80	100	125	160	200	250	300	320

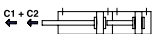
FORZE TEORICHE A 6 BAR THEORETICAL FORCES AT 6 BAR

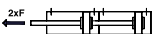
Ø (mm)	Forza di spinta (N) Thrust force (N)	Forza di trazione (N) Traction force (N)
125	7359	6877
160	12058	11304
200	18840	18086

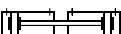
VARIANTI VARIANTS

Simbolo Symbol	Caratteristiche Features	Simbolo Symbol	Caratteristiche Features
	Resistente alle alte temperature -10...+150°C Heat-resistant -10...+150°C		Filettature e steli su richiesta Custom made thread or piston rod
	Resistente alle basse temperature -40...+80°C Low temperature resistant -40...+80°C		Guarnizione stelo ad elevata resistenza chimica Rod seal with increased chemical resistance
	Stelo prolungato Piston rod extension		Configurazione tandem a più posizioni Multi position configuration
	Basso attrito Low friction		Configurazione tandem a doppia spinta Double thrust tandem configuration
	Stelo in acciaio inox Stainless steel piston rod		Configurazione tandem contrapposti anteriore Front opposed tandem configuration
	Lubrificazione FDA FDA lubrication		Configurazione tandem contrapposti posteriore Rear opposed tandem configuration

CILINDRI COMPATTI Ø125-200 COMPACT CYLINDERS Ø125-200

**DOPPIO EFFETTO
DOUBLE ACTING**

CDEØ/...KNF

CDEMØ/...KNF

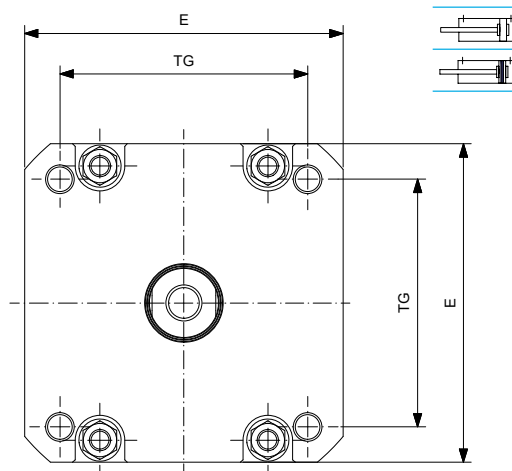
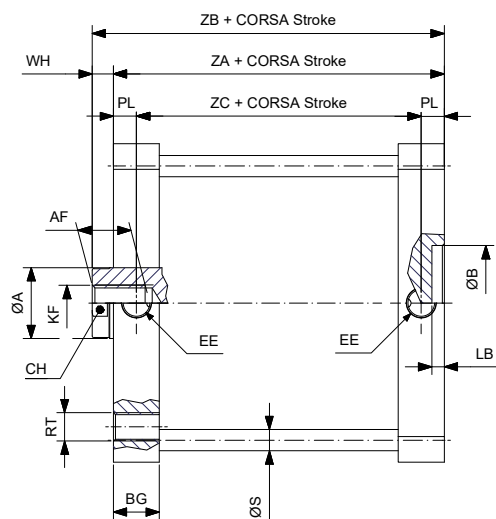

Ømm	ØA	CH	AF	WH	ZA	ZB	ZC	KF	EE	TG	E	RT	PL	ØB	LB	ØS	BG
125	32	27	25	10	78	88	58	M16X2	1/4"G	110	145	M12X1.75	10	60	7	10	20.25
160	40	36	30	12	87	99	61	M20X2.5	3/8"G	140	180	M16X2	13	65	7	12	26
200	40	36	30	12	87	99	61	M20X2.5	3/8"G	175	220	M16X2	13	75	7	12	26

**DOPPIO EFFETTO PASSANTE
DOUBLE ACTING THROUGH PISTON ROD**

CDEPØ/...KNF

CDEMPØ/...KNF

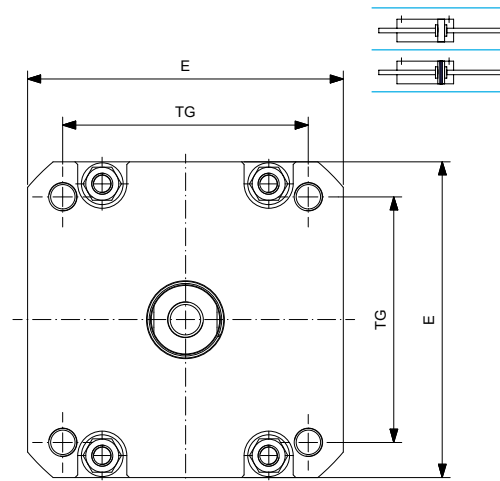
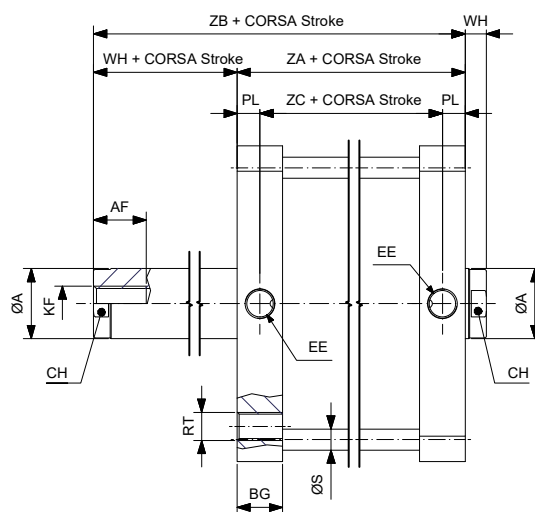

Ømm	ØA	CH	AF	WH	ZA	ZB	ZC	KF	EE	TG	E	RT	PL	ØS	BG
125	32	27	25	10	78	88	58	M16X2	1/4"G	110	145	M12X1.75	10	10	20.25
160	40	36	30	12	87	99	61	M20X2.5	3/8"G	140	180	M16X2	13	12	26
200	40	36	30	12	87	99	61	M20X2.5	3/8"G	175	220	M16X2	13	12	26

DOPIO EFFETTO
DOUBLE ACTING

CDEØ/...KNM

CDEMØ/...KNM

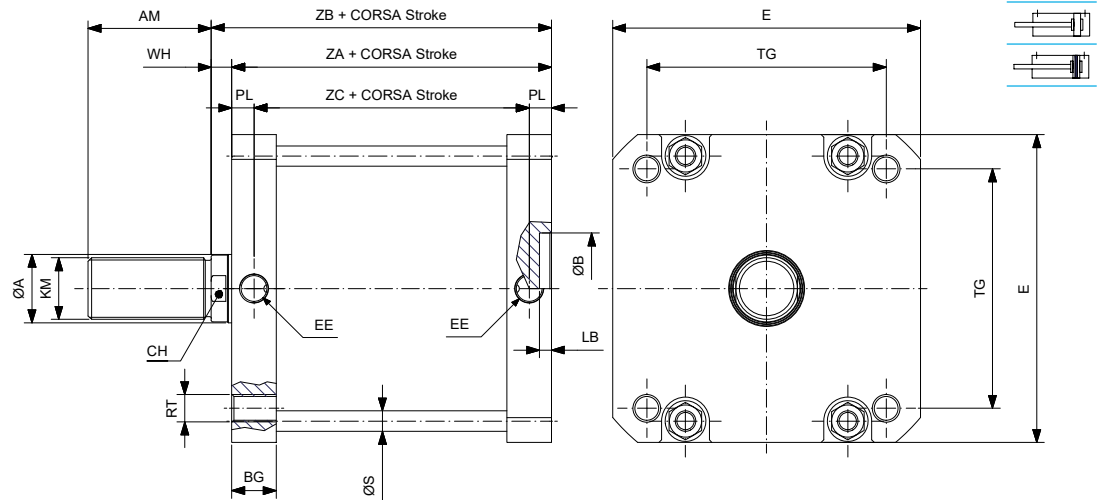

Ømm	ØA	CH	AM	WH	ZA	ZB	ZC	KM	EE	TG	E	RT	PL	ØB	LB	ØS	BG
125	32	27	54	10	78	88	58	M27X2	1/4"G	110	145	M12X1.75	10	60	7	10	20.25
160	40	36	72	12	87	99	61	M36X2	3/8"G	140	180	M16X2	13	65	7	12	26
200	40	36	72	12	87	99	61	M36X2	3/8"G	175	220	M16X2	13	75	7	12	26

DOPIO EFFETTO PASSANTE
DOUBLE ACTING THROUGH PISTON ROD

CDEPØ/...KNM

CDEMPØ/...KNM

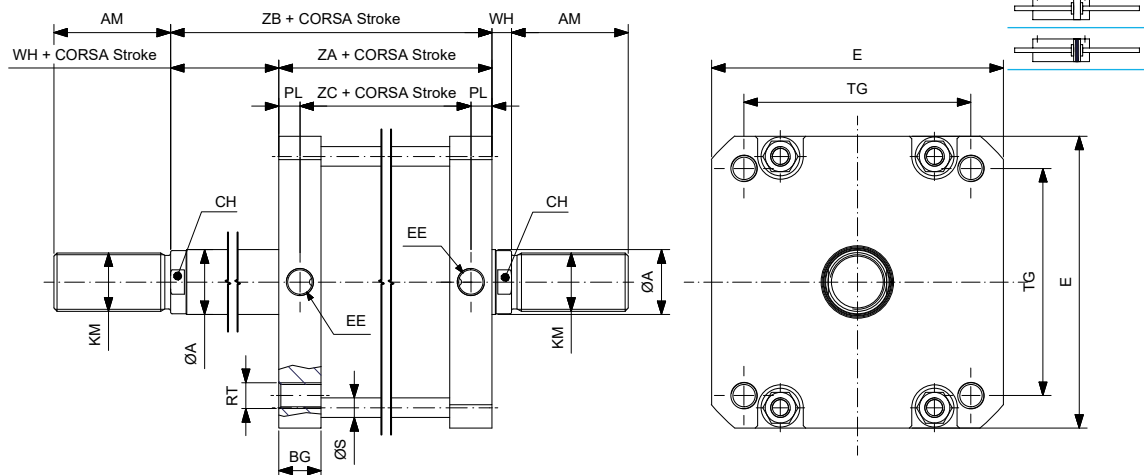

Ømm	ØA	CH	AM	WH	ZA	ZB	ZC	KM	EE	TG	E	RT	PL	ØS	BG
125	32	27	54	10	78	88	58	M27X2	1/4"G	110	145	M12X1.75	10	10	20.25
160	40	36	72	12	87	99	61	M36X2	3/8"G	140	180	M16X2	13	12	26
200	40	36	72	12	87	99	61	M36X2	3/8"G	175	220	M16X2	13	12	26

CILINDRI COMPATTI Ø125-200 COMPACT CYLINDERS Ø125-200

ACCESSORI DI FISSAGGIO MOUNTING ACCESSORIES

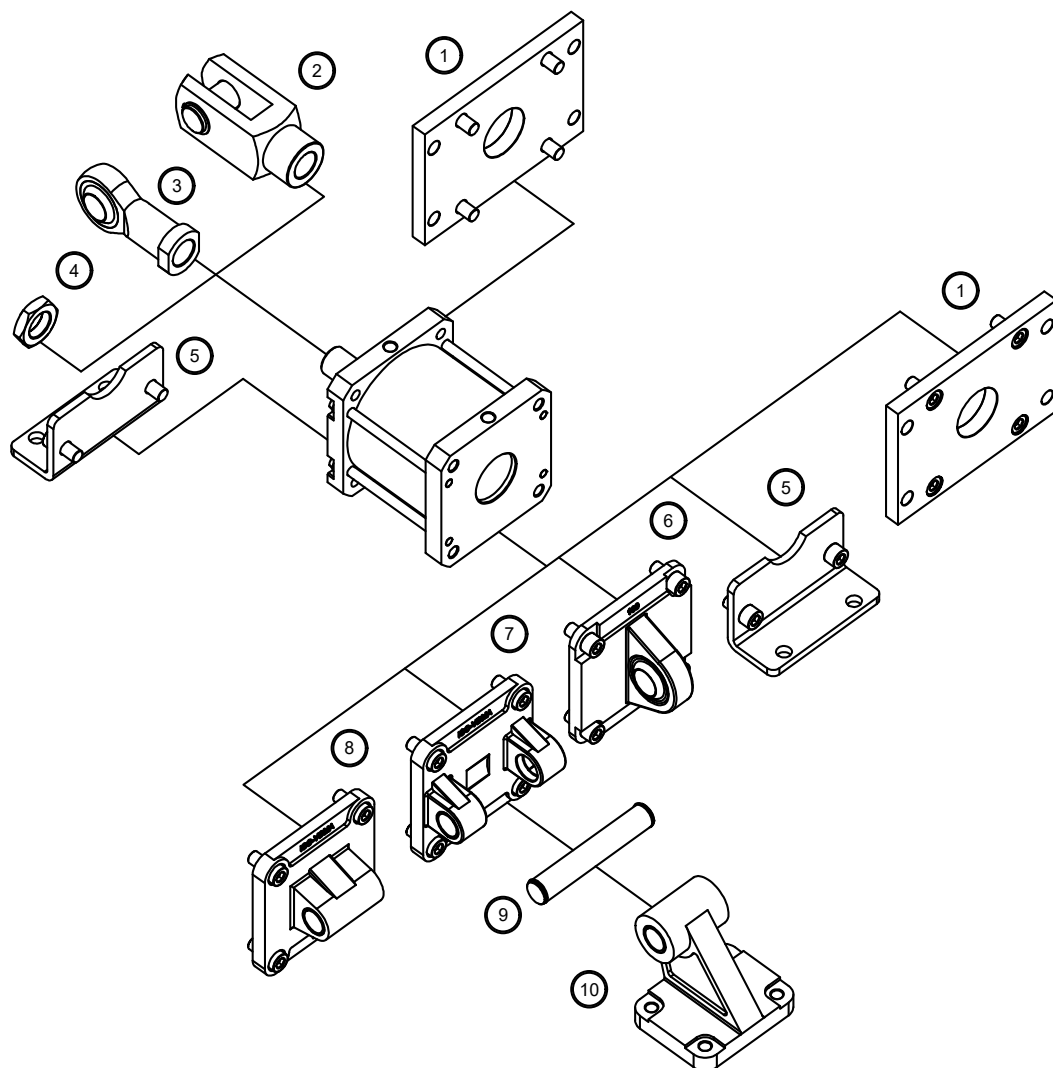

Descrizione Description	Alluminio Aluminium	Acciaio Steel	Acciaio inox Stainless steel
1 Flangia / Flange (MF1-MF2)	-	139	-
2 Forcella / Clevis	-	132	147
3 Testa a snodo / Rod end	-	132	148
4 Dado per aste / Piston rod nut	-	130	146
5 Piedino basso / Low-rise pedestal (MS1)	-	138	152
6 Cerniera maschio snodata / Male hinge with spherical bearing (MP6)	137	143	-
7 Cerniera femmina / Female hinge (MP2)	134	142	150
8 Cerniera maschio / Male hinge (MP4)	135	-	151
9 Perno per cerniera femmina / Pivot for female hinge (AA4)	-	135	150
10 Articolazione a squadra / Square joint (AB7)	137	-	-
11 Giunto autoallineante / Self-aligning joint	-	131	-